



IFS DOCUMENTATION

PART I: OBSERVATION PROCESSING (CY23R4)

Edited by Peter W. White

(Text written and updated by members of the ECMWF Research Department)



Table of contents

[Chapter 1.](#) Non-IFS observation processing (OBSPROC): General overview

[Chapter 2.](#) Observations: Types, variables and error statistics

[Chapter 3.](#) CMA creation (MAKEMA)

[Chapter 4.](#) The FEEBACK task

[Chapter 5.](#) The TOOLS task

[Chapter 6.](#) Central-memory array (CMA) structure/format

[Chapter 7.](#) BUFR feedback data structure/format

[Chapter 8.](#) SIMULATED-observations data structure/format

[Chapter 9.](#) NAMELISTS

[Chapter 10.](#) Processing of scatterometer data

[REFERENCES](#)





Part I: OBSERVATION PROCESSING**CHAPTER 1 Non-IFS observation processing (OBSPROC): General overview****Table of contents**[1.1 Basic principles](#)[1.2 Data structures and formats](#)[1.3 Main tasks and functions](#)[1.4 Data assimilation data flow and OBSPROC's role in it](#)[1.5 Invoking, initializing and controlling the OBSPROC](#)**1.1 BASIC PRINCIPLES**

The ECMWF data assimilation observation processing system is split into two parts:

- 1) the non-IFS observation processing module (OBSPROC), and
- 2) the IFS processing module (IFS).

The main separation line what is done in one or the other module is based on whether a field (e.g. first guess) information is required or not. Thus, the observation processing functions for which field information is not required are dealt with by the OBSPROC, whereas the IFS deals with the observation processing functions for which field information are required. The OBSPROC is also known as the pre-analysis observation handling system.

The main purpose of the OBSPROC is threefold:

- 1) to pre-process the input data for further use by the analysis (IFS),
- 2) to post-process data used by the analysis, and
- 3) to provide some observation processing related diagnostics/debugging tools.

The observation processing/handling in the ECMWF data assimilation system has become very complex. This is mainly due to an increased volume and variety of observations together with more advanced analysis techniques and computers.

The idea is to have:

- (a) efficient,
- (b) transparent,
- (c) low maintenance, and
- (d) comprehensive

observation processing system so that all the variational analysis observational requirements, in both the operational and the research contexts, can be met. On the efficiency side the use of massively parallel processing (MPP) computers led to a fully parallelized observation processing system. The transparency requirement meant that both the code and the data structuring had to be computer independent. When considering the observation processing system maintenance, the view taken was that it had to be organised in such a way, first, that it should be controlled as much as it is possible externally (no code changes) via namelists and, second, that the code should be modular enough so that when there is a need to change or expand it (for new observations) it can be done with a relative

ease. By the comprehensiveness of the system it is meant that only a few job steps (modules) ought to perform all observation processing tasks as well as to accommodate for the future requirements.

Generally speaking, OBSPROC is a namelist driven module with appropriate defaults preset. There are 15 namelists altogether for now (see [Chapter 9 'NAMELISTS'](#)).

The OBSPROC module can be used in two modes:

- (a) single task (workstation version), and
- (b) parallel (MPP version).

Parallelization of the OBSPROC was necessary because:

- the expansion of a large non-homogenous data sets may be time-consuming,
- some other computational work is also done at the same time,
- on a parallel machine each individual processor tends to be 'slow' (especially in scalar mode),
- memory requirements for observations processing may be very large,
- an MPP may lend itself naturally to distributed data, and
- past and present experience shows that the single task job steps are a source of bottle necks.

Although the parallelization aspects of the observation processing are dealt with by a separate module called OBSORT, the OBSPROC is achieving parallelization by a number of the OBSORT subroutine calls. Effectively, the OBSPROC code is the same for both the parallelized and the single task modes. The parallel version is activated by a namelist parameter.

Either of these two OBSPROC modes consists of a number of observation processing tasks, while in turn each task consists of a number of observation processing functions (see [Section 1.3](#)).

1.2 DATA STRUCTURES AND FORMATS

Three main observational data structures/formats for both the input and the output are recognised by the OBSPROC. These data structures are:

- 1) BUFR (for details see ECMWF Meteorological Bulletin M1.4/4),
- 2) Central Memory Array or CMA (for details see [Chapter 6 'Central-memory array \(CMA\) structure/format'](#)), and
- 3) SIMULATED OBSERVATIONS (for details see [Chapter 8 'SIMULATED-observations data structure/format'](#)).

All these three data structures/formats, depending on which task is being executed, can be both the input and the output data structures/formats.

Furthermore, there are a few OBSPROC internal diagnostics/debugging data structures/formats (for details see [Chapter 5 'The TOOLS task'](#)).

1.3 MAIN TASKS AND FUNCTIONS

By looking at all the observation related data assimilation activities for which no field information is required it is evident that they can be very different in their nature. Therefore, three main activities are identified and they represent three OBSPROC's tasks:

- 1) CMA file(s) creation or MAKECMA task (see [Chapter 3 'CMA creation \(MAKECMA\)'](#)),
- 2) BUFR feedback file(s) creation or FEEDBACK task (see [Chapter 4 'The FEEDBACK task'](#)), and



- 3) observation processing diagnostic/debugging activities or TOOLS task (see Chapter 5 'The TOOLS task').

The main purpose of the MAKECMA task is to create the output data set suitable for further use by the analysis. This is achieved by performing a number of observation processing functions. In brief, these functions include:

- reading in the input data,
- extracting and crudely checking necessary informations,
- changing observed variables into the actually used ones by the analysis (e.g. wind direction and speed are converted into the wind components u and v),
- assigning observation errors,
- reformatting extracted informations and storing them into the output data structure/format,
- etc.

The main aim of the FEEDBACK task is to append the input BUFR data with all observation related informations gathered during the data assimilation cycle. These appended data sets are then used as an input for diagnostics runs and archiving.

The TOOLS task, as such, is not necessary for running the data assimilation cycle. However, a number of observation processing related activities outside the data assimilation cycle can be identified. These activities include a need, sometime, to:

- print both the BUFR and the CMA reports for a given observation type and geographical area,
- reformat data,
- perform various diagnostics runs and checks,
- carry out various debugging activities,
- etc..

For these reasons it is decided to have a unified tool by which one can perform all these activities. Unlike with the previous tasks, only the single-task version of the TOOLS task is available.

1.4 DATA ASSIMILATION DATA FLOW AND OBSPROC'S ROLE IN IT

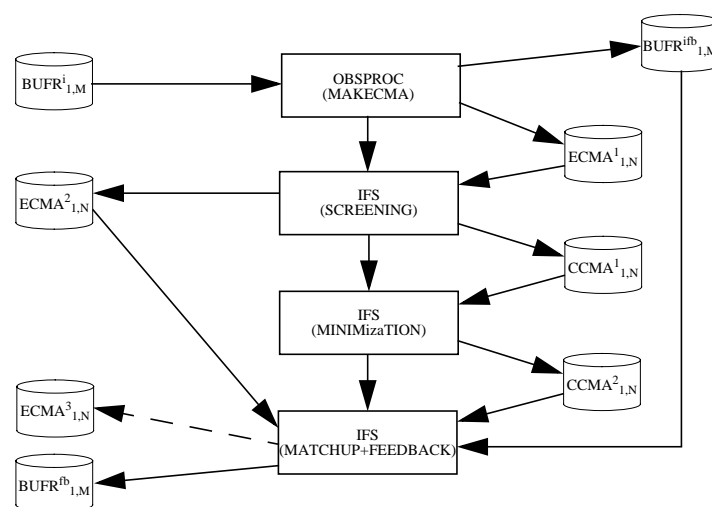

Figure 1.1 General data-assimilation data flow

Fig. 1.1 shows data flow in the data assimilation system cycle with the OBSPROC's role in it. Data assimilation system is invoked by starting up the OBSPROC's task MAKECMA. MAKECMA reads input BUFR data (files), extracts all necessary informations and creates so called Expanded CMA (ECMA) file. Here, it is important to note that for each ECMA report there is also its BUFR counterpart with one to one correspondence created and written out onto a separate so called initial BUFR feedback file. Only the ECMA file is then passed on to the IFS screening run for further processing. During the screening run various observation related informations are stored in the ECMA and after performing all its activities it creates so called Compressed CMA (CCMA) file for the IFS minimization run. Note: the ECMA is still in one to one correspondence with the BUFR but not with the CCMA. Although the CCMA file contains only a subset of the ECMA (both in terms of observation reports and pieces of information) the actual numbers are identical at this stage. While the minimization (analysis) is being carried out the CCMA is being constantly updated with fresh observation related informations. After the minimization has finished the FEEDBACK task is started. The idea here is to feedback (append) all observation related informations gathered in the data assimilation cycle onto the original input BUFR data. These feedback informations are: flags, events, black list informations, departures etc. The actual feedback is effectively passing over informations from the ECMA file to the initial BUFR feedback file, bearing in mind the one to one correspondence between them. However, at this stage there are two CMA files, ECMA and CCMA, with the ECMA not updated for the informations stored during the minimization. Hence, the FEEDBACK task has its sub-task called **MATCHUP** which purpose is to bring back the relevant CCMA file content into the ECMA. The **MATCHUP** sub-task is realised by an appropriate call to the OBSORT from the FEEDBACK task. Upon completing the **MATCHUP** the actual feedback takes place. The FEEDBACK task output data structure/format is the appended initial BUFR feedback file. These feedback BUFR files, after running some diagnostics, are then archived. As it can be noted, the OBSPROC's TOOLS task does not figure out in this data flow.

1.5 INVOKING, INITIALIZING AND CONTROLLING THE OBSPROC

OBSPROC is invoked via program **AAOBPPRO** which in turn immediately calls the main controlling subroutine **CNTOBSPR** (Fig. 1.2). It is in this subroutine that it is decided what to do next. First, from the environment variables it is found whether it is a parallel or a single task run. This is done by calling **UTIL_IGETENV** subroutine. Then, several logical switches are preset and the basic I/O units defined. These presets are mainly to prepare things for a possible parallel run. Also, an initial setup of the OBSORT is carried out by calling the OBSORT subroutine **SETUP_OBSORT**.

The next step is to find out which task is to be carried out. As mentioned in Section 1.1, OBSPROC is a namelist driven module. Thus, the NAMELIST handling is initialized (**ININAM**), first, and the top level namelist NAMRUN is read in (**READNL**) next. The NAMRUN namelist contains, at the moment, 16 logical switches (for details see Chapter 9 'NAMELISTS' and Section 9.1). By setting one or more of those switches to **.TRUE.** an appropriate task/mode will be activated. Not all the NAMRUN namelist parameters are relevant for each task/mode. **LMKCM**, **LFEEDBAC** and **LTOOLS** are the **MAKECMA**, the **FEEDBACK** and the **TOOLS** tasks switches, respectively. **LMPP** is the mode switch. All the other switches are to help in choosing how certain aspects of running the task are dealt with.

Once it is established what task and in which mode to run it, **CNTOBSPR** branches itself off into a section dedicated to that task. This is shown in Fig. 1.3. What is actually done in a task section and underneath will be discussed in chapters dedicated to the relevant OBSPROC's tasks. However, regardless of which task section it ended up in, they all straight away will perform a preliminary initialization of various parameters and additional switches. This initialization consists of defining:

- I/O units (**SUIOD**),



- various numerical constants (SUNUMC),
- various common parameters (SETCOM), and
- run settings (DEFRUN).

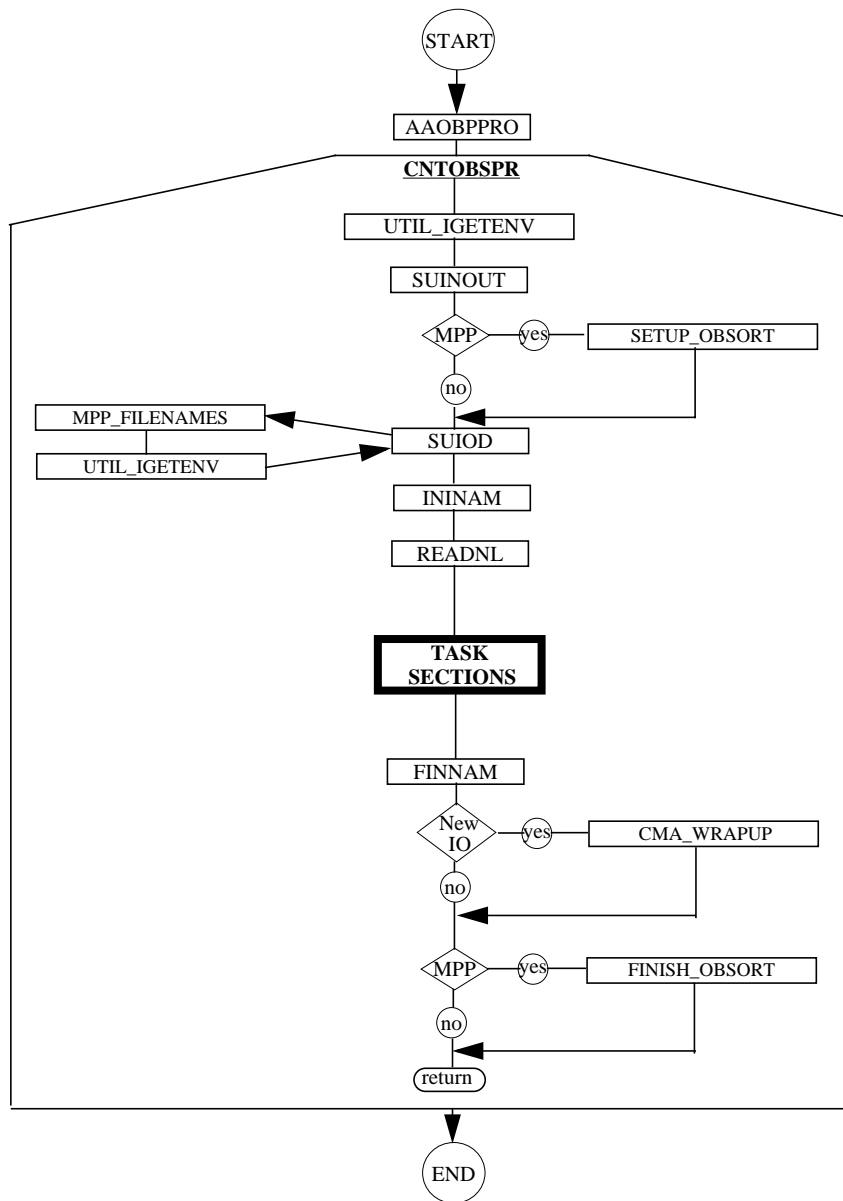

Figure 1.2 Invoking and controlling of the OBSPROC

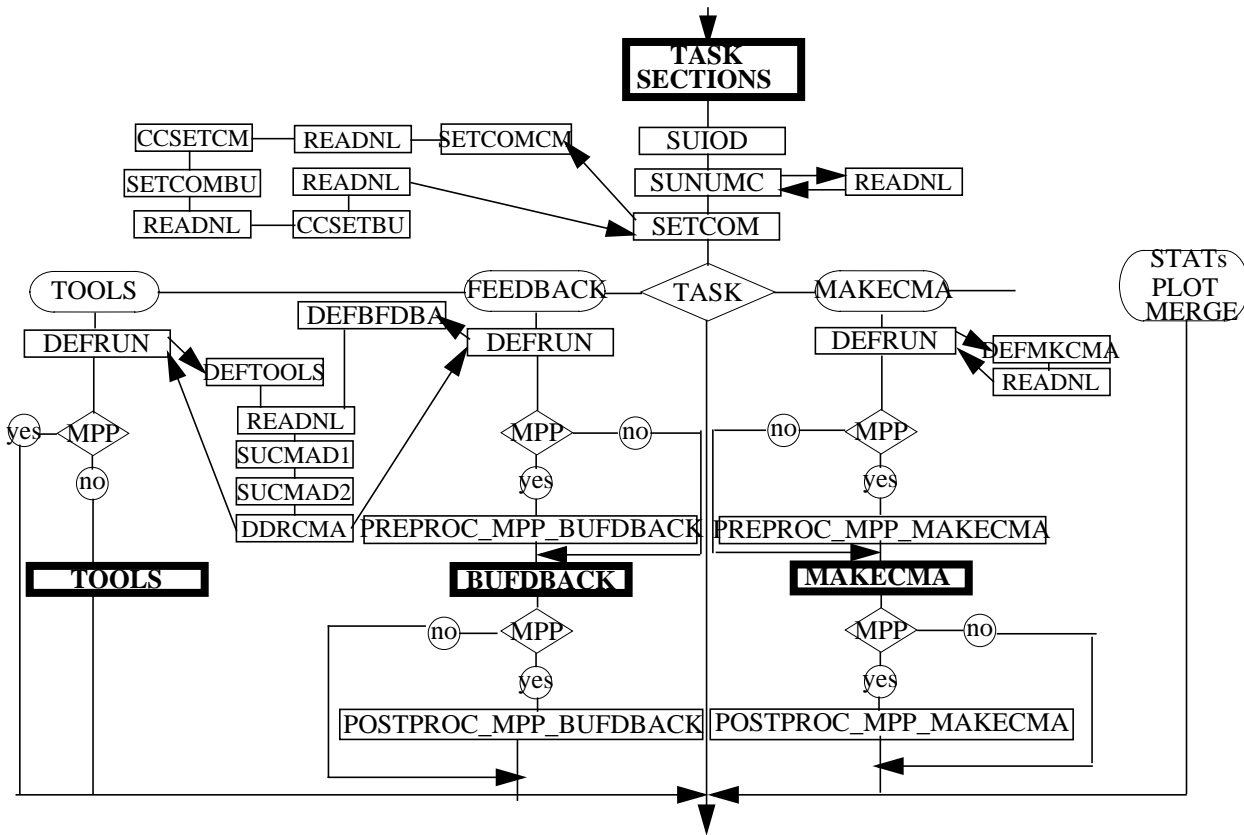

Figure 1.3 OBSPROC's main-tasks branch-off flow diagram

In the context of operational running, the MAKECMA task is started by having:

- LMKCMA=.T.,LCMASORT=.T., LMPP=.T., LCOLLECT=.F.

and all the rest set to .FALSE.. This particular choice of LMKCMA and LMPP setting is obviously to run MAKECMA task in a parallel mode. The choice of setting for LCMASORT switch means that sorting of both the BUFR and the CMA data is activated. The aim of this sorting is to achieve a reasonable data distribution across processing elements (PEs) with a view to getting a good load balance. On the other hand, the choice of setting for LCOLLECT switch means that the number of output files is equal to the number of PEs used, alternatively they would be collected into one output file.

When it comes to running the FEEDBACK task in the operational context switches are set as follows:

- LFEEDBAC=.T., LBFDBACK=.T., LMPP=.T.,LCOLLECT=.T., LMATCHUP=.T.

and with all the rest set to .FALSE.. Regarding the LMATCHUP switch there will be more said about it later in the chapter dedicated to the FEEDBACK task.

Various settings of switches for the TOOLS task will be explained in the chapter dedicated to this task.



Part I: OBSERVATION PROCESSING

CHAPTER 2 Observations: Types, variables and error statistics

Table of contents

2.1 Observation types, subtypes and code types

2.1.1 BUFR observation types and subtypes

2.1.2 CMA observation types and code types

2.1.3 CMA observation types and code types mapping to/from BUFR observation types and subtypes

2.1.4 Observed, derived and adjusted variable

2.1.5 Observed variables

2.1.6 Derived variables

2.1.7 Adjusted variables

2.1.8 Variables' codes

2.2 Observation error statistics

2.2.1 Persistence error

2.2.2 Prescribed observational errors

2.2.3 Derived observation errors

2.2.4 Final (combined) observation error

2.1 OBSERVATION TYPES, SUBTYPES AND CODE TYPES

All observations, both in the BUFR and the CMA contexts, are split in a number of observation types. The observation types are then further divided into observation code types (CMA) and observation subtypes (BUFR).

2.1.1 BUFR observation types and subtypes

There are 8 BUFR observation types. However, number of subtypes differs from observation type to observation type. They are defined in **SUBUOCTP** subroutine and listed here



TABLE 2.1 BUFR OBSERVATION TYPES AND SUBTYPES

Observation types		Subtypes	
Code no.	Name	Code no.	Name
0	Land surface	1	Land SYNOP
		2	High-level land SYNOP (invented)
		3	Automatic land SYNOP
		4	High-level automatic land SYNOP
		9	Abbreviated SYNOP
		10	High-level abbreviated SYNOP (invented)
		1	Sea surface
11	SHIP 1		
13	Automatic SHIP		
19	Reduced SHIP		
21	DRIBU		
22	BATHY		
23	TESAC		
2	Upper-air soundings	91	Land PILOT
		92	SHIP PILOT
		95	Wind profiler
		101	Land TEMP
		102	SHIP TEMP
		103	DROP TEMP
3	Satellite soundings	106	Mobile TEMP
		0	High-resolution TOVS
		51	High-resolution TOVS
		53	RTOVS
		54	ATOVS
		61	Low-level temperature SATEM
		62	High-level temperature SATEM
		63	PWC SATEM
		65	Merged SATEM
		71	Low-level temperature TOVS
		72	High-level temperature TOVS
73	PWC TOVS		
75	Merged TOVS		
161	PAOB		



TABLE 2.1 BUFR OBSERVATION TYPES AND SUBTYPES

Observation types		Subtypes	
4	AIREP	142	AIREP
		143	COLBA
		144	AMDAR
		145	ACARS
5	SATO	82	Temperature and wind
		83	Wind only
		84	Temperature only 1
		85	Temperature only 2
		86	High-resolution VIS wind
		87	AMV
12	ERS/SSMI	8	ERS 1
		122	ERS 2
		127	SSMI
253	PAOB	164	PAOB

2.1.2 CMA observation types and code types

There are 10 CMA observation types with different number of code types for each of them. They are defined in **SUCMOCTP** subroutine and listed here too

TABLE 2.2 CMA OBSERVATION TYPES AND CODE TYPES

Observation types		Code types	
Code no.	Name	Code no.	Name
1	SYNOP	11	Manual land station
		14	Automatic land station
		21	SHIP
		22	SHIP abbreviated
		23	SHRED
		24	Automatic SHIP
2	AIREP	41	CODAR
		141	Aircraft
		142	Simulated
		144	AMDAR
		145	ACARS
		241	COLBA

TABLE 2.2 CMA OBSERVATION TYPES AND CODE TYPES

Observation types		Code types	
3	SATOB	88	SATOB
		89	High-resolution VIS wind
		90	AMV
		188	SST
4	DRIBU	63	BATHY
		64	TESAC
		160	ERS as DRIBU
		165	DRIBU
5	TEMP	35	Land
		36	SHIP
		37	Mobile
		39	Land ROCOB
		40	SHIP ROCOB
		135	DROP
		137	Simulated
6	PILOT	32	Land
		33	SHIP
		34	Wind Profilers
7	SATEM	86	GTS
		184	High-resolution simulated DWL TOVS
		185	High-resolution simulated DWL SATEM
		186	High resolution
		200	GTS BUFR 250 km
		201	GTS BUFR Clear Radiance
		202	GTS BUFR retrieved profiles/clear radiances
		210	ATOVS
		211	RTOVS
		212	TOVS
215	SSMI		
8	PAOB	180	PAOB
9	SCATTEROMETER	8	Scatterometer 1
		122	Scatterometer 2
		210	Scatterometer 3
10	RAW RADIANCES	1	%



2.1.3 CMA observation types and code types mapping to/from BUFR observation types and subtypes

TABLE 2.3 CMA OBSERVATION AND CODE TYPES MAPPED INTO BUFR OBSERVATION TYPES AND SUBTYP

CMA(ObsType,CodeType)	⇒ BUFR(ObsType,Subtype)
CMA(1,11)	⇒ BUFR[(0, 1);(0, 9)]
CMA(1, 14)	⇒ BUFR[(0, 3); (0, 4)]
CMA(1,21)	⇒ BUFR[(1, 9); (1, 11)]
CMA(1, 22)	⇒ BUFR()
CMA(1, 23)	⇒ BUFR(1, 19)
CMA(1, 24)	⇒ BUFR(1, 13)
CMA(2, 41)	⇒ BUFR()
CMA(2, 141)	⇒ BUFR(4, 142)
CMA(2, 142)	⇒ BUFR()
CMA(2, 144)	⇒ BUFR(4, 144)
CMA(2, 145)	⇒ BUFR(4, 145)
CMA(2, 241)	⇒ BUFR(4, 143)
CMA(3, 88)	⇒ BUFR[(5, 82);(5, 83);(5, 84);(5, 85)]
CMA(3, 89)	⇒ BUFR(5, 86)
CMA(3, 90)	⇒ BUFR(5, 87)
CMA(3, 188)	⇒ BUFR()
CMA(4, 63)	⇒ BUFR(1, 23)
CMA(4, 64)	⇒ BUFR(1, 22)
CMA(4, 160)	⇒ BUFR()
CMA(4, 165)	⇒ BUFR(1, 2)
CMA(5, 35)	⇒ BUFR(2, 101)
CMA(5, 36)	⇒ BUFR(2, 102)
CMA(5, 37)	⇒ BUFR(2, 106)
CMA(5, 39)	⇒ BUFR()
CMA(5, 40)	⇒ BUFR()
CMA(5, 135)	⇒ BUFR(2, 103)
CMA(5, 137)	⇒ BUFR()
CMA(6, 32)	⇒ BUFR(2, 91)
CMA(6, 33)	⇒ BUFR(2, 92)
CMA(6, 34)	⇒ BUFR(2, 95)
CMA(7, 86)	⇒ BUFR[(3,61);(3, 62);(3, 63);(3,65)]
CMA(7, 184)	⇒ BUFR()

TABLE 2.3 CMA OBSERVATION AND CODE TYPES MAPPED INTO BUFR OBSERVATION TYPES AND SUBTYP

CMA(7, 185)	⇒ BUFR()
CMA(7, 186)	⇒ BUFR[(3, 71):(3, 72):(3, 73):(3, 75)]
CMA(7, 200)	⇒ BUFR()
CMA(7, 201)	⇒ BUFR()
CMA(7, 202)	⇒ BUFR()
CMA(7, 210)	⇒ BUFR(3, 54)
CMA(7, 211)	⇒ BUFR(3, 53)
CMA(7, 212)	⇒ BUFR[(3, 0):(3, 51)]
CMA(7, 215)	⇒ BUFR(12, 127)
CMA(8, 180)	⇒ BUFR(253, 164)
CMA(9, 8)	⇒ BUFR(12, 8)
CMA(9, 122)	⇒ BUFR(12, 122)
CMA(9, 210)	⇒ BUFR()
CMA(10, 1)	⇒ BUFR()

2.1.4 Observed, derived and adjusted variable

TABLE 2.4 BUFR OBSERVATION TYPES AND SUBTYPES MAPPED INTO CMA OBSERVATION AND CODE TYPES

BUFR(ObsType,Subtype)	⇒ CMA(ObsType,CodeType)
BUFR(0, 1)	⇒ CMA(1, 11)
BUFR(0, 3)	⇒ CMA(1, 14)
BUFR(0, 4)	⇒ CMA(1, 14)
BUFR(0, 9)	⇒ CMA(1, 11)
BUDR(1, 9)	⇒ CMA(1, 21)
BUFR(1, 11)	⇒ CMA(1, 21)
BUFR(1, 13)	⇒ CMA(1, 24)
BUFR(1, 19)	⇒ CMA(1, 23)
BUFR(1, 22)	⇒ CMA(4, 64)
BUFR(1, 23)	⇒ CMA(4, 63)
BUFR(2, 91)	⇒ CMA(6, 32)
BUFR(2, 92)	⇒ CMA(6, 33)
BUFR(2, 95)	⇒ CMA(6, 34)
BUFR(2, 101)	⇒ CMA(5, 35)
BUFR(2, 102)	⇒ CMA(5, 36)
BUFR(2, 103)	⇒ CMA(5, 135)



TABLE 2.4 BUFR OBSERVATION TYPES AND SUBTYPES MAPPED INTO CMA OBSERVATION AND CODE TYPES

BUFR(2, 106)	⇒ CMA(5, 37)
BUFR(3, 0)	⇒ CMA(7, 212)
BUFR(3, 51)	⇒ CMA(7, 212)
BUFR(3, 53)	⇒ CMA(7, 211)
BUFR(3, 54)	⇒ CMA(7, 210)
BUFR(3, 61)	⇒ CMA(7, 86)
BUFR(3, 62)	⇒ CMA(7, 86)
BUFR(3, 63)	⇒ CMA(7, 86)
BUFR(3, 65)	⇒ CMA(7, 86)
BUFR(3, 71)	⇒ CMA(7, 186)
BUFR(3, 72)	⇒ CMA(7, 186)
BUFR(3, 73)	⇒ CMA(7, 186)
BUFR(3, 75)	⇒ CMA(7, 186)
BUFR(4, 142)	⇒ CMA(2, 141)
BUFR(4, 143)	⇒ CMA(2, 241)
BUFR(4, 144)	⇒ CMA(2, 144)
BUFR(4, 145)	⇒ CMA(2, 145)
BUFR(5, 82)	⇒ CMA(3, 88)
BUFR(5, 83)	⇒ CMA(3, 88)
BUFR(5, 84)	⇒ CMA(3, 88)
BUFR(5, 85)	⇒ CMA(3, 88)
BUFR(5, 86)	⇒ CMA(3, 89)
BUFR(5, 87)	⇒ CMA(3, 90)
BUFR(12, 8)	⇒ CMA(9, 8)
BUFR(12, 122)	⇒ CMA(9, 122)
BUFR(12, 127)	⇒ CMA(7, 125)
BUFR(253, 164)	⇒ CMA(8, 180)

Different quantities are observed by the different observing systems. It is only a subset of the observed quantities that are used in the analysis and most of them are used as such. However, some of them are transformed into the ones actually used by the analysis. This transformation, or a change of variable, may also include retrieval from satellite data if they are independent from the background model fields. The original variables may be kept with the derived ones so that first guess departures can be assigned for both. Furthermore, if an observed variable is transformed then, if necessary, so also are its observation error statistics. Also, in the case of an off-time SYNOP observation, the observed surface pressure may be adjusted.

2.1.5 Observed variables

The exact list of what is observed or present in the above mentioned list of BUFR observation types and subtypes is defined in the OBSPROC in terms of BUFR templates. These BUFR templates consist of definitions for BUFR:

- descriptors,
- names, and
- units.

Various BUFR observation type/subtype templates are defined in the following subroutine:

- **SETBLANS** (land surface):
 - **SETBLSNO** (normal land surface),
 - **SETBLSHI** (high land surface),
- **SETBSEAS** (sea surface),
- **SETBUPPA** (upperair soundings),
- **SETBSATS** (satellite soundings):
 - **SETBSSHI** (high resolution tovs/rtovs/atovs),
 - **SETBSSLT** (satem/tovs low level temperatures),
 - **SETBSSHT** (satem/tovs high level temperatures),
 - **SETBSSPW** (satem/tovs pwc),
 - **SETBSSME** (merged satem/tovs),
- **SETBAIRE** (aireps)
- **SETBSATO** (satobs),
- **SETBSCAT** (ers),
- **SETBSSMI** (ssmis), and
- **SETBPAOB** (paobs).

As it can be seen some of these routines (**SETBLANS** and **SETBSATS**) are further granulated to define some subtypes separately.

Here, we will try to list (per observation types) those variables which are at the moment of our interest:

TABLE 2.5 OBSERVED VARIABLES

BUFR observation type	Observed variables
Land surface	Surface pressure (p_s) 10 m wind direction / force (DDD/FFF) 2 m temperature 2 m dew point ($T_{d\ 2m}$) Pressure tendency (p_t) Cloud informations Precipitation information Snow depth (S_d) etc.



TABLE 2.5 OBSERVED VARIABLES

BUFR observation type	Observed variables
Sea Surface	Surface pressure (p_s) 10 m wind direction/force (DDD/FFF) 2 m temperature 2 m dew point (T_{d2m}) etc.
Upper-air sounding	10 m / upper-air wind direction / force (DDD/FFF) 2 m / upper-air temperature (T_{2m} / T) 2m / upper-air dew point (T_{d2m} / T) Geopotential height (Z)
Satellite sounding	Mean layer temperatures Precipitable water content (PWC) Brightness temperatures (T_b)
Airep	Upper-air wind direction / force (DDD/FFF) Temperature (T)
Satob	Upper-air wind direction / force (DDD/FFF)
ERS	Backscatter (σ_0) Brightness temperature (T_b)

2.1.6 Derived variables

Variables which are transformed for further use by the analysis are:

- wind direction (DDD) and force (FFF) are transformed into wind components (u and v) for SYNOP, AIREP, SATOB, DRIBU, TEMP and PILOT observations,
- temperature (T) and dew point (T_d) are transformed into relative humidity (RH) for SYNOP and TEMP observations, with a further transformation of the RH into specific humidity (Q) for TEMP observations,
- SCATTEROMETER backscatters (σ_0 's) are transformed into a pair of ambiguous wind components (u and v); this actually involves a retrieval according to some model function describing the relationship between winds and σ_0 's and requires a fair bit of computational work,
- mean layer temperature is transformed into thickness (DZ) for SATEM and TOVS observations.

All these variable transformations, except for the σ_0 's transformation, are more or less trivial ones.

The wind components are worked out as:

$$u = -FFF \sin\left(DDD \frac{\pi}{180}\right)$$

$$v = (-FFF) \cos\left(DDD \frac{\pi}{180}\right)$$

The RH is derived by using the following relationship:

$$RH = \frac{F(T_d)}{F(T)}$$

where function F of either T or T_d is expressed as:

$$F(T) = 611.21 \frac{R_{\text{dry}}}{R_{\text{vap}}} \left[W(T) \left\{ \exp\left(a \frac{T - T_0}{T - c}\right) + (1 - W(T)) \exp\left(b \frac{T - T_0}{T - d}\right) \right\} \right]$$

where, $T_0 = 273.16 K$, $a = 17.502$, $b = 22.587$, $c = 32.19$, $d = -0.7$, $R_{\text{dry}} = 287.0597$ and $R_{\text{vap}} = 461.5250$ are constants, whereas function W of either T or T_d is given:

$$W(T) = \min \left[1, \left\{ \frac{\max[T_0 - 23, \min(T_0, T)] - (T_0 - 23)}{T_0 - (T_0 - 23)} \right\}^2 \right]$$

Specific humidity Q is worked out by using the following relationship:

$$Q = RH \frac{A}{1 - [RH \{(R_{\text{vap}}/R_{\text{dry}}) - 1\} A]}$$

where, p is pressure and function A is expressed as:

$$A = \min \left(0.5, \frac{F(T)}{p} \right)$$

Q is worked out in subroutine RH2Q.

Exact details of the scatterometer wind retrieval are dealt with in [Chapter 10 'Processing of scatterometer data'](#).

2.1.7 Adjusted variables

The only observed quantity which is adjusted is the SYNOP's surface pressure (p_s). This is done by using the pressure tendency (p_t) information, which in turn may be first adjusted (SYNOP SHIP) for the ship movement.

The ship movement information is available from the input data in terms of ship speed and direction, which are first converted into ship movement components U_s and V_s . The next step is to find pressure gradient ($\partial p/\partial x$ and $\partial p/\partial y$):

$$\frac{\partial p}{\partial x} = C(A_1 v - A_2 u)$$

$$\frac{\partial p}{\partial y} = -C(A_1 u + A_2 v)$$

where u and v are observed wind components. C is a Coriolis term multiplied by a drag coefficient (D):

$$C = 2\Omega \sin\theta D$$

where, θ is the latitude, $\Omega = 0.7292 \times 10^{-4} \text{s}^{-1}$ is the angular velocity of the earth and D is expressed as:



$$D = GZ$$

where, $G = 1.25$ is an assumed ratio between geostrophic and surface wind over sea and $Z = 0.11 \text{ kg m}^{-3}$ is an assumed air density. Now the adjusted pressure tendency (p_t^a) can be found as:

$$p_t^a = p_t - \left(U_s \frac{\partial p}{\partial x} + V_s \frac{\partial p}{\partial y} \right)$$

Finally, the adjusted surface pressure (p_s^a) is found as:

$$p_s^a = p_s - p_t^a \Delta t$$

where, Δt is a time difference between analysis and observation. Of course in the case of non-ship data $p_t^a \equiv p_t$.

Subroutine PTENDCOR is used for this adjustment.

2.1.8 Variables' codes

For an easy recognition of 'observed' variables every each of them is assigned its numerical code. These numerical codes are then embedded in CMA reports. There are 68 codes used so far. These codes are defined in **SUVNMB** subroutine. Once again for the sake of completeness we are listing them here too.

TABLE 2.6 VARIABLES' NUMBERING

No.	Code	Variable	Unit
1	3	u	m s^{-1}
2	4	v	m s^{-1}
3	1	Geopotential (Z)	$\text{m}^2 \text{s}^{-2}$
4	57	Thickness (DZ)	$\text{m}^2 \text{s}^{-2}$
5	29	Relative humidity (RH)	Numeric
6	9	Precipitable water content (PWC)	kg m^{-2}
7	58	2m relative humidity (RH_{2m})	Numeric
8	2	Temperature (T)	K
9	59	Dew point (T_d)	K
10	39	2m temperature (T_{2m})	K
11	40	2m dew point (T_{d2m})	K
12	11	Surface temperature (T_s)	K
13	30	Pressure tendency (p_t)	Pa/3h
14	60	Past weather (W)	WMO code 4561
15	61	Present weather (WW)	WMO code 4677
16	62	Visibility (V)	WMO code 4300
17	63	Type of high clouds (C_H)	WMO code 0509
18	64	Type of middle clouds (C_M)	WMO code 0515

TABLE 2.6 VARIABLES' NUMBERING

No.	Code	Variable	Unit
19	65	Type of low clouds (C_L)	WMO code 0513
20	66	Cloud base height (N_h)	m
21	67	Low cloud amount (N)	WMO code 2700
22	68	Additional cloud group height ($h_s h_s$)	m
23	69	Additional cloud group type (C)	WMO code 0500
24	70	Additional cloud group amount (N_s)	WMO code 2700
25	71	Snow depth (S_d)	m
26	72	State of ground (E)	WMO code 0901
27	73	Ground temperature ($T_g T_g$)	K
28	74	Special phenomena ($S_p S_p$)	WMO code 3778
29	75	Special phenomena ($s_p s_p$)	WMO code 3778
30	76	Ice code type (R_s)	WMO code 3551
31	77	Ice thickness ($E_s E_s$)	WMO code 1751
32	78	Ice (I_s)	WMO code 1751
33	79	Time period of rain information ($t_r t_r$)	hour
34	80	6hr rain amount	kg m ⁻²
35	81	Maximum temperature (JJ)	K
36	82	Ship speed (V_s)	m s ⁻¹
37	83	Ship direction (D_s)	Degree
38	84	Wave height ($H_w H_w$)	m
39	85	Wave period ($P_w P_w$)	s
40	86	Wave direction ($D_w D_w$)	Degree
41	87	General cloud group	WMO code 20012
42	88	Relative humidity from low clouds	Numeric
43	89	Relative humidity from middle clouds	Numeric
44	90	Relative humidity from high clouds	Numeric
45	91	Total amount of clouds	WMO code 20011
46	92	6 hr snowfall	m
47	110	Surface pressure (p_s)	Pa
48	111	Wind direction	Degree
49	112	Wind force	m s ⁻¹
50	119	Brightness temperature (T_b)	K
51	120	Raw radiance	K
52	121	Cloud amount from satellite	%
53	122	Backscatter (σ_0)	dB
54	5	Wind shear ($\partial u / \partial z$)	s ⁻¹



TABLE 2.6 VARIABLES' NUMBERING

No.	Code	Variable	Unit
55	6	Wind shear $\partial v/\partial z$	s^{-1}
56	41	u_{10m}	$m s^{-1}$
57	42	v_{10m}	$m s^{-1}$
58	19	Layer relative humidity	Numeric
59	200	Auxiliary variable	Numeric
60	123	Cloud liquid water (Q_1)	$kg kg^{-1}$
61	124	Ambiguous v	$m s^{-1}$
62	125	Ambiguous u	$m s^{-1}$
63	7	Specific humidity (Q)	$kg kg^{-1}$
64	126	Ambiguous wind direction	Degree
65	127	Ambiguous wind speed	$m s^{-1}$
66	8	Vertical speed	$m s^{-1}$
67	56	Virtual temperature T_v	K
68	130	Ozone	Dobson

2.2 OBSERVATION ERROR STATISTICS

Three types of observation errors are dealt with at this level:

- persistence error,
- prescribed observation error and,
- combination of these two above, so called final observation error.

2.2.1 Persistence error

The persistence error is formulated in such a way to reflect its dependence on:

- a season, and
- the actual geographical position of an observation.

Seasonal dependency is introduced by identifying three regimes:

- winter/summer hemispheres and,
- tropics,

and then positional dependency is introduced to reflect a dependence on the precise latitude within these three regimes.

The persistence error calculation is split in two parts. In the first part the above dependencies are expressed in terms of factors a and b which are defined as:

$$a = \sin\left(2\pi \frac{d}{365.25} + \frac{\pi}{2}\right)$$

and

$$b = 1.5 + a[0.5 \min\{\max(\theta, 20)\}/20]$$

where, d is a day of year and θ is latitude.

The persistence error for time difference between analysis and observation Δt is then expressed as a function of b with a further dependence on latitude and a maximum persistence error ($E_{\max\text{pers}}$) for 24 hours:

$$E_{\text{pers}} = \frac{E_{\max\text{pers}}}{6} \{1 + 2 \sin(|2\theta|)\} b \Delta t$$

where, Δt is expressed as a fraction of a day. The $E_{\max\text{pers}}$ has the values as shown in the table below:

TABLE 2.7 MAXIMUM 24-HOUR PERSISTENCE ERRORS

Variable (unit)	1000–700 hPa	699–250 hPa	249–0 hPa
u, v (m s ⁻¹)	6.4	12.7	19.1
Z (m)	48	60	72
T (K)	6	7	8

Subroutine **SUPERERR** is used to define all relevant points in order to carry out this calculation, and is called only once during the general system initialization. The calculation of the actual persistence error is dealt by subroutine **OBSPERR**.

2.2.2 Prescribed observational errors

Prescribed observational errors have been derived by statistical evaluation of the performance of the observing systems, as components of the assimilation system, over a long period of operational use. The prescribed observational errors are given in the tables below. Currently, observational errors are defined for:

- wind components,
- height,
- temperature, and
- relative humidity

for each observation type which carries these quantities. As it can be seen from the tables below, they are defined at standard pressure levels but the actually used ones are interpolated to the observed pressures. The interpolation is such that the observation error is kept constant below the lowest and above the highest levels, whereas in between it is interpolated linearly in $\ln(p)$. Several subroutines are used for working out the prescribed observation error. These subroutines are: **SUOBSERR**, **OBSERR**, **FIXERR**, **THIOERR** and **PWCOERR**. In **SUOBSERR** observation errors are defined for standard pressure levels. In **OBSERR** and **FIXERR** the actual values are worked out. **THIOERR** and **PWCOERR** are two specialised subroutines to deal with thickness and *PWC* errors.

Relative humidity observation error (RH_{err}) is either prescribed or modelled. More will be said about the modelled RH_{err} in the next subsection. RH_{err} is prescribed only for TEMP and SYNOP data. RH_{err} is preset to 0.17 for TEMP and 0.13 for SYNOP. However, if $RH < 0.2$ it is increased to 0.23 and to 0.28 if $T < 233$ K for both TEMP and SYNOP:



$$RH_{err(TEMP)} = \begin{cases} 0.23 & \text{if } RH < 0.2 \\ 0.28 & \text{if } T < 233 \text{ K} \\ 0.17 & \text{otherwise} \end{cases}$$

$$RH_{err(SYNOP)} = \begin{cases} 0.23 & \text{if } RH < 0.2 \\ 0.28 & \text{if } T < 233 \text{ K} \\ 0.13 & \text{otherwise} \end{cases}$$

TABLE 2.8 THE RMS OBSERVATION WIND COMPONENTS (u AND v) ERRORS (m s^{-1})

Obs. types	Levels														
	1000 hPa	850 hPa	700 hPa	500 hPa	400 hPa	300 hPa	250 hPa	200 hPa	150 hPa	100 hPa	70 hPa	50 hPa	30 hPa	20 hPa	10 hPa
synop	3.0	3.0	3.0	3.4	3.6	3.8	3.2	3.2	2.4	2.2	2.0	2.0	2.0	2.5	3.0
airep	2.5	2.5	3.0	3.5	4.0	4.0	4.0	4.0	4.0	4.0	4.0	4.0	4.0	4.0	4.0
satob	2.0	2.0	2.0	3.5	4.3	5.0	5.0	5.0	5.0	5.0	5.0	5.0	5.0	5.0	5.7
dribu	2.4	2.4	2.5	3.4	3.6	3.8	3.2	3.2	2.4	2.2	2.0	2.0	2.0	2.5	3.0
temp	2.3	2.3	2.5	3.0	3.5	3.7	3.5	3.5	3.4	3.3	3.2	3.2	3.3	3.6	4.5
pilot	2.3	2.3	2.5	3.0	3.5	3.7	3.5	3.5	3.4	3.3	3.2	3.2	3.3	3.6	4.5
satem	%	%	%	%	%	%	%	%	%	%	%	%	%	%	%
paob	%	%	%	%	%	%	%	%	%	%	%	%	%	%	%
scat	2.0	2.0	2.0	2.0	2.0	2.0	2.0	2.0	2.0	2.0	2.0	2.0	2.0	2.0	2.0
r.raid	%	%	%	%	%	%	%	%	%	%	%		%	%	%

TABLE 2.9 THE RMS OBSERVATION HEIGHT ERRORS (m)

Obs. type	Levels														
	1000 hPa	850 hPa	700 hPa	500 hPa	400 hPa	300 hPa	250 hPa	200 hPa	150 hPa	100 hPa	70 hPa	50 hPa	30 hPa	20 hPa	10 hPa
synop	7.0	8.0	8.6	12.1	14.9	18.8	25.4	27.7	32.4	39.4	50.3	59.3	69.8	96.0	114.2
airep	%	%	%	%	%	%	%	%	%	%	%	%	%	%	%
satob	%	%	%	%	%	%	%	%	%	%	%	%	%	%	%
dribu	11.5	11.5	17.2	24.2	29.8	37.6	50.8	55.4	64.8	78.8	100.6	118.6	139.6	192	228.4
temp	4.3	4.4	5.2	8.4	9.8	10.7	11.8	13.2	15.2	18.1	19.5	22.5	25.0	32.0	40.0
pilot	4.3	4.4	5.2	8.4	9.8	10.7	11.8	13.2	15.2	18.1	19.5	22.5	25.0	32.0	40.0
satem	%	%	%	%	%	%	%	%	%	%	%	%	%	%	%
paob	24.0	24.0	24.0	24.0	24.0	24.0	24.0	24.0	24.0	24.0	24.0	24.0	24.0	24.0	24.0
scat	%	%	%	%	%	%	%	%	%	%	%	%	%	%	%
r rad.	%	%	%	%	%	%	%	%	%	%	%	%	%	%	%

TABLE 2.10 THE RMS OBSERVATION TEMPERATURE ERRORS (K)

Obs. Types	Levels														
	1000 hPa	850 hPa	700 hPa	500 hPa	400 hPa	300 hPa	250 hPa	200 hPa	150 hPa	100 hPa	70 hPa	50 hPa	30 hPa	20 hPa	10 hPa
synop	2.0	1.5	1.3	1.2	1.3	1.5	1.8	1.8	1.9	2.0	2.2	2.4	2.5	2.5	2.5
airep	1.4	1.3	1.2	1.2	1.2	1.3	1.3	1.4	1.4	1.4	1.5	1.6	1.8	2.0	2.2
satob	%	%	%	%	%	%	%	%	%	%	%	%	%	%	%
dribu	1.8	1.5	1.3	1.2	1.3	1.5	1.8	1.8	1.9	2.0	2.2	2.4	2.5	2.5	2.5
temp	1.7	1.5	1.3	1.2	1.2	1.4	1.5	1.5	1.6	1.7	1.8	1.9	2.0	2.2	2.5



TABLE 2.10 THE RMS OBSERVATION TEMPERATURE ERRORS (K)

Obs. Types	Levels														
	1000 hPa	850 hPa	700 hPa	500 hPa	400 hPa	300 hPa	250 hPa	200 hPa	150 hPa	100 hPa	70 hPa	50 hPa	30 hPa	20 hPa	10 hPa
pilot	%	%	%	%	%	%	%	%	%	%	%	%	%	%	%
satem	%	%	%	%	%	%	%	%	%	%	%	%	%	%	%
paob	%	%	%	%	%	%	%	%	%	%	%	%	%	%	%
scat	%	%	%	%	%	%	%	%	%	%	%	%	%	%	%
r. rad.	%	%	%	%	%	%	%	%	%	%	%	%	%	%	%

2.2.3 Derived observation errors

Relative humidity observation error, RH_{err} , can also be expressed as function of temperature (T):

$$RH_{\text{err}} = \min\{0.18, \max(0.06, -0.0015 T + 0.54)\}$$

This option is currently used for assigning RH_{err} .

Specific humidity observation error (Q_{err}) is a function of relative humidity and its observation error (RH, RH_{err}), pressure and its error (p, p_{err}) and temperature and its error (T, T_{err}), and formally can be expressed as:

$$Q_{\text{err}} = Q_{\text{err}}(RH, RH_{\text{err}}, p, p_{\text{err}}, T, T_{\text{err}})$$

or:

$$Q_{\text{err}} = RH_{\text{err}} F_1(RH, p, T) + RH p_{\text{err}} F_2(RH, p, T) + RH T_{\text{err}} F_3(RH, p, T)$$

where, functions F_1, F_2, F_3 are given as:

$$F_1(RH, p, T) = \frac{A}{\left[1 - RH \left(\frac{R_{\text{vap}}}{R_{\text{dry}}} - 1\right) A\right]^2}$$

$$F_2(RH, p, T) = \frac{\frac{A}{p} \left[\left[1 - RH \left(\frac{R_{\text{vap}}}{R_{\text{dry}}} - 1\right) A\right] + \frac{R_{\text{vap}}}{R_{\text{dry}}} A \right]}{\left[1 - \left[RH \left(\frac{R_{\text{vap}}}{R_{\text{dry}}} - 1\right) A \right]\right]^2}$$

$$F_3(RH, p, T) = W(T) F_4(RH, p, T) + (1 - W(T)) F_5(RH, p, T)$$

and functions F_4, F_5 are:

$$F_4(RH, p, T) = \frac{Aa(T_0 - c)}{(T - c)^2} \left[\left\{ 1 - \left(\frac{R_{\text{vap}}}{R_{\text{dry}}} - 1 \right) A \right\} + RH A \left(\frac{R_{\text{vap}}}{R_{\text{dry}}} - 1 \right) \right]$$

$$F_5(RH, p, T) = \frac{Ab(T_0 - d)}{(T - d)^2} \left[\left\{ 1 - \left(\frac{R_{\text{vap}}}{R_{\text{dry}}} - 1 \right) A \right\} + RH A \left(\frac{R_{\text{vap}}}{R_{\text{dry}}} - 1 \right) \right]$$

At the moment only the first term of the above expression for Q_{err} is taken into account (dependency on relative humidity). Subroutine **RH2Q** is used to evaluate Q_{err} .

The surface-pressure observation error ($p_{\text{s(terr)}}$) is derived by multiplying the height observation error (Z_{err}) by a constant:

$$p_{\text{s(terr)}} = 1.225 \cdot Z_{\text{err}}$$

However, the $p_{\text{s(terr)}}$ may be reduced if the pressure-tendency correction is applied. In the case of non-ship data the reduction factor is 4, whereas in the case of ship data the reduction factor is either 2 or 4, depending if the p_t is adjusted for ship movement or not.

The thickness observation error (DZ_{err}) is derived from the Z_{err} .

2.2.4 Final (combined) observation error

In addition to the prescribed observation and persistence errors, the so called final observation error is assigned at this stage too. The final observation error is simply a combination of the observation and the persistence errors:

$$FOE = \sqrt{OE^2 + PE^2}$$

where, FOE, OE and PE are final, prescribed observation and persistence errors, respectively. The subroutine used for this purpose is **FINOERR**.



Part I: OBSERVATION PROCESSING**CHAPTER 3 CMA creation (MAKECMA)****Table of contents**

3.1 Input and output data

3.2 Calling-tree structure

3.2.1 MAKECMA

3.2.2 MKCMASIN and MKCMAMPP

3.2.3 SCANBUFR

3.2.4 OBSCREEN

3.2.5 Basic observation handling routines

3.1 INPUT AND OUTPUT DATA

Only two data structures/formats, BUFR and CMA, are recognised. The input data are always in BUFR structure/format, whereas the output data are always in CMA and BUFR structure/format. However, in the case of SIMULATED observations, since their structure/format (see [Chapter 8 ‘SIMULATED-observations data structure/format’](#)) is neither BUFR nor CMA, they are first converted (see [Chapter 5 ‘The TOOLS task’](#)) into an intermediate SIMULATED observation structure/format which is then subjected to another conversion into the BUFR structure/format. There may be up to seven input BUFR files. Although, at the moment there are only four input BUFR files. They are called: CONVENTIONAL, TOVS, SCATTEROMETER and SSMI files and each of them contains those types of observations, respectively. On the output there is one CMA and one BUFR file, per PE, containing data of all types.

3.2 CALLING-TREE STRUCTURE

As explained in [Section 1.5](#), after finding out in the main controlling subroutine **CNTOBSPR** that the **MAKECMA** task is to be run, and after branching off into that section of the subroutine, the real **MAKECMA** task can start (see [Fig. 1.3](#)). If the **MAKECMA** task is to be run in parallel mode, subroutine **PREPROC_MPP_MAKECMA** is called next. It is this subroutine which will by a number of the **OBSORT** subroutine calls invoke the parallel processing. Somewhere down in the **OBSORT** the input BUFR files are then read in and BUFR messages distributed across PEs (to get an initial load balance) and eventually written out as one ‘sorted BUFR file’ per PE. Once the **PREPROC_MPP_MAKECMA** has finished, the control is returned back to the **CNTOBSPR**. The next step is to call **MAKECMA** subroutine (more details are given in the next subsection).

After the **MAKECMA** has completed its work, the control is handed back to the **CNTOBSPR**. Again, if it is a parallel run subroutine **POSTPROC_MPP_MAKECMA** (see [Fig. 1.3](#)) is called, otherwise the task is about to finish. The main purpose of the **POSTPROC_MPP_MAKECMA** subroutine is the following. The CMA data, and for that matter their BUFR counterparts, are scattered across PEs in a semi-random way. This may be a reasonable distribution to start with when we know very little about the input data. However, now that we know much more about the input data and, by combining that knowledge and our knowledge of what work is going to be done in the IFS

with the data, we are in a better position to do an additional re-distribution of the input data with a view to getting a reasonable load balance within the IFS. It is via this subroutine, and the subsequent calls to the other relevant OBSORT subroutines, that a shuffle and eventual write out of both the CMA and the initial feedback BUFR data is done. The number of files written out will either be a single one, or one per PE. Which of this two options is taken depends on the status of the NAMRUN namelist switch LCOLLECT.

3.2.1 MAKECMA

The flow diagram of this subroutine is shown in Fig. 3.1 . The main purpose of this subroutine is threefold:

- 1) to initialize various **MAKECMA** task parameters and switches,
- 2) to print out the chosen run set-up, and
- 3) to invoke either the single task (**MKCMASIN**) or the parallel (**MKCMAMPP**) data processing.

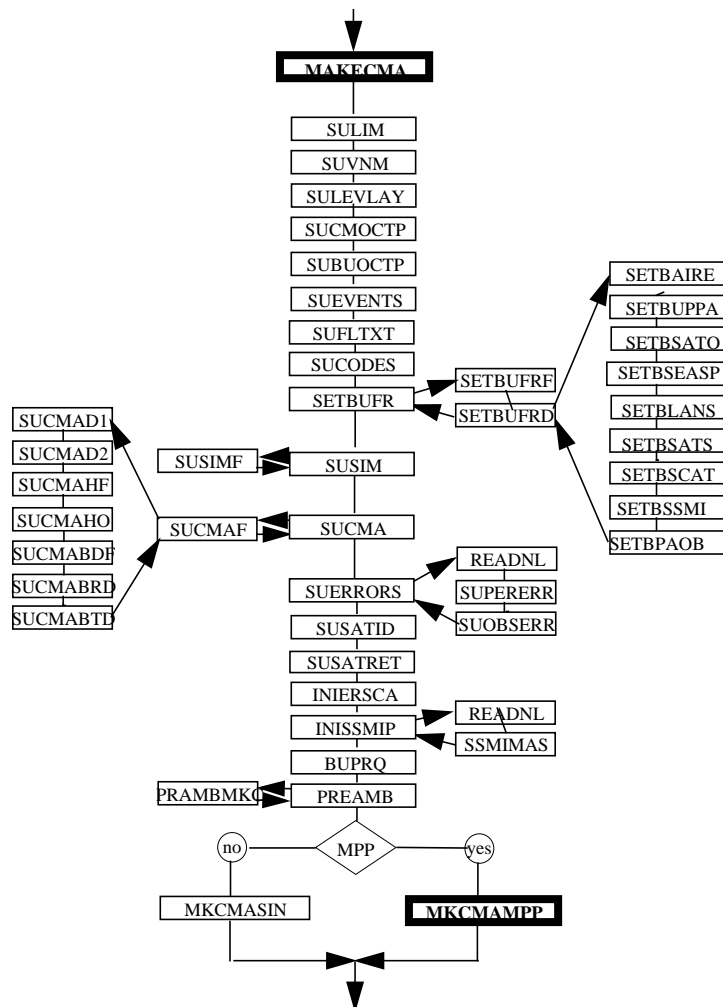

Figure 3.1 Subroutine MAKECMA flow diagram

The setting of the parameters and switches within the initialization consists of defining:

- numerical limits (SULIM),
- variables' numbers (SUVNMB),
- level/layers structure (SULEVLAY),



- CMA observation and code types (SUCMOCTP),
- BUFR observation types and subtypes (SUBUOCTP),
- observation events (SUEVENTS),
- observation flags (SUFLTXT),
- various observation processing codes (SUCODES),
- BUFR data structure and format (SETBUFR),
- SIMULATED data structure and format,
- CMA data structure and format (SUCMA),
- observation error specification (SUERRORS),
- valid satellite ids (SUSATID),
- satellite retrieval types (SUSATRET),
- SCATTEROMETR observation processing options (INIERSCA),
- SSMI observation processing options (INISSMIP), and
- appropriate setting for BUFR software (BUPRQ).

Once the OBSPROC is initialized, the chosen run set-up is printed (**PREAMB**). The next step, depending on whether the parallel or single-task option is chosen, is to call either subroutine **MKCMAMPP** or **MKCMASIN**, respectively.

3.2.2 **MKCMASIN** and **MKCMAMPP**

There is not much difference between these two subroutines. The main difference is in the way the observation sequence number is handled. **MKCMAMPP** flow diagram is shown in [Figure 3.2](#).

The observation sequence number is a unique number assigned to each observation. This number, in the single task case is simply incremented (starting from 1), whereas in the parallel case a list is created. Observation sequence number list creation is independent of how many PEs are used. This is a very important point with respect to achieving computational reproducibility later on in the IFS.

However, both of these two subroutines, after some initial preset, open up input/output files. BUFR input and output files are initialised by calling **INIIBUFF** and **INIOBUFF** subroutines, whereas the CMA file is initialised via a call to **INICMAIO** subroutine. BUFR debugging/diagnostic files are initialised via calls to **INIDEBDE**, **INIDEBEN** and **INIDEBRE** subroutines. Also, a preset of various counters and pointers takes place.

The initialization of all files, except the input BUFR, consists of simply opening them up. The decision on which BUFR input files are to be initialized is controlled by a set of logical NAMBUFR namelist switches. These switches are: LCONVF, LTOVSF, LATOVF, LSCATF, LSSMIF, LGEOSF and LAUXBF. They control the presence of input BUFR files for: CONVENTIONAL, TOVS, ATOVS, SCATTEROMETER, GEOSTATIONARY, SSMI and any other BUFR data. The decision on how many input BUFR files are to be initialized at this stage, depends on whether the single-task or parallel version is used. In the-single task version it may be up to 7 files per data time window. However, in the parallel case the input BUFR files would have already been read in and data distributed across the PEs. As mentioned earlier the distribution of the input BUFR files is such that there is one BUFR file per PE containing all observation types. Due to this, the original BUFR files presence switches are turned off except for the BUFR auxiliary file LAUXBF. Regardless which way was used to reach this point, the **INIIBUFF** subroutine is called. A BUFR input file is first opened up and its data descriptor record (DDR) read in. If the DDR is present, the file date and time are extracted and checked against the analysis date and time. However, if the DDR is not present the very first BUFR message is read in and the date and time are taken for the date/time checking (allowing for data time window which is currently ± 3 hours). If the date/time check fails further processing is stopped. Upon a successful date/time check and if the BUFR input data are to be held in memory (the NAMBUFR namelist parameter LIBUFMER=.T.) subroutine **BUFRLoad** is called to read the whole file in, after which the control is handed back.

The next step is to create preliminary CMA data descriptors (DDRs). This is done by calling **CMADDR** subroutine. After this, the main input BUFR data cracking subroutine (**SCANBUFR**) is invoked, and upon its completion the control is returned back. It is only now that the proper CMA DDRs can be created by recalling the **CMADDR** subroutine and linking it up with the rest of the CMA data (CMA2CMO). Some BUFR and CMA data processing information are printed next by calling **BUFRSTA** and **CMASTA** subroutines, respectively. The only thing left to do at this stage is to close off the files. The BUFR input and output files are closed by calling subroutines **FINIBUFF** and **FINOBUFF**, respectively. The CMA file is closed by calling subroutine **FINCMAIO**. The debugging/diagnostics files are closed by calling **FINDEBDE**, **FINDEBEN** and **FINDEBRE** subroutines.

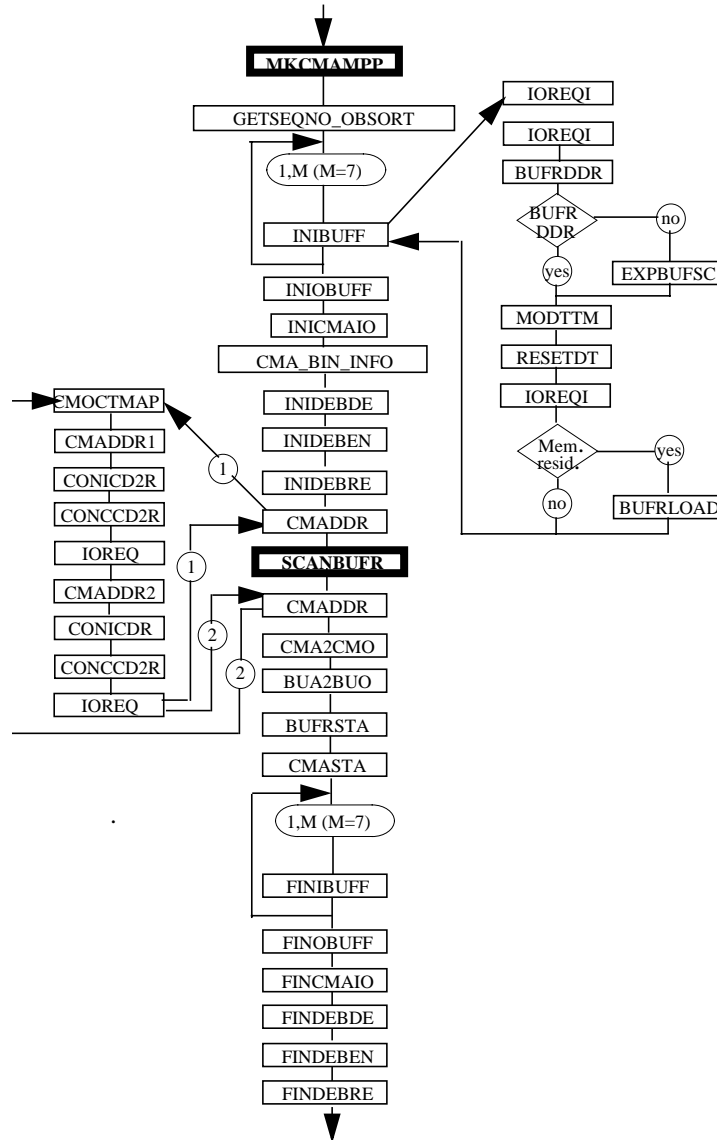
 Figure 3.2 Subroutine **MKCMAMPP** flow diagram

3.2.3 **SCANBUFR**

The main purpose of this subroutine, the flow diagram for which is shown in [Figure 3.3](#), is to loop over all input BUFR messages. Once it gets hold of a BUFR message it expands BUFR sections 0, 1 and 2 and hands over further

processing to subroutine **OBSCREEN**. Subroutine **GETIBUFR** is used to get a single BUFR message. Depending on whether the input BUFR data are file or memory resident (the NAMBUFR namelist parameter LIBUFMER=.F/.T.) data either have been read in, or have just been copied. BUFR sections 0, 1 and 2 are expanded by calling **EXPBUFSC** subroutine. From these BUFR sections a few parameters (BUFR edition number, observation type and subtype) are taken. The BUFR edition number is checked and, if it is not expected, further processing is stopped. Also, the BUFR observation type and subtype are mapped onto the OBSPROC internal numbers (BUOCTMAP). At this stage, it is possible to skip certain BUFR messages by consulting the NAMDIA namelist NSKIPBR array. Also, a range of consecutive BUFR messages can be written out; this is controlled by the NAMDIA namelist parameters NBURAN1 and NBURAN2. Furthermore, a compressed BUFR message can be uncompressed by calling **BOPRPRO** and **SPLITCR** subroutines. After all this, further observation processing is handed to the **OBSCREEN** subroutine.

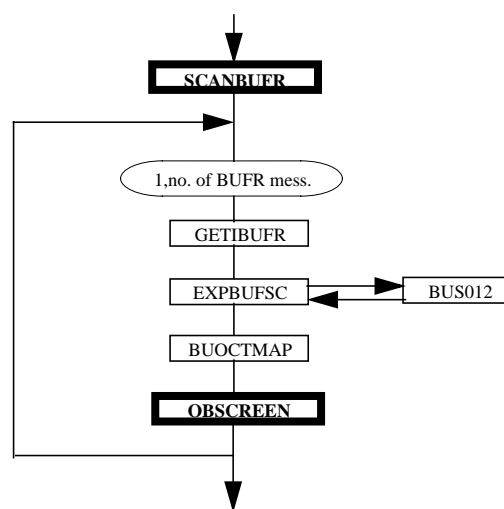

Figure 3.3 Subroutine **SCANBUFR** flow diagram

3.2.4 **OBSCREEN**

On its arrival to this subroutine (see [Figure 3.4](#)), BUFR sections are expanded again and several BUFR parameters are cross-checked. Also, at this stage the number of BUFR reports present in a message is found. The BUFR observation type and subtype are then mapped into the OBSPROC internal numbers by calling **BUOCTMAP** subroutine. A selection of BUFR messages which go further is made here next. This selection is based on examining appropriate observation-type/subtype switches which are held in the NAMGLP namelist. For a complete list of switches see the description of the NAMGLP namelist in [Chapter 9 'NAMELISTS'](#) .

The actual expansion of the BUFR messages takes place next by calling the **EXPBUFR** subroutine. The expanded BUFR message format is checked against its predefined template by calling the **BUFRFOT** subroutine. For some BUFR land-surface subtypes, there are two valid templates; hence it is difficult to know which one to use for this type of check. For this reason these subtypes are checked against both templates, and the subtype changed to an internally invented one in order to avoid this confusion later on. In the case of the incoming BUFR message being compressed (more than one BUFR report), a preparation for its uncompression takes place next by calling **PRE-SPLIT** subroutine.

In the next step some preparation is done for possible CMA report creation. From the BUFR observation type and the subtype, the corresponding CMA observation type and code type are found by calling the **BUF2CMAT** subroutine. The CMA observation type and code type are then mapped into the OBSPROC internal sequence numbers by

calling **CMOCTMAP**. Also, the lengths of the CMA header and body entry are worked out by calling **GETHEADL** and **GETBODYL**, respectively.

Now the processing of BUFR reports can start. First, the observation sequence number is assigned. The way this is done depends, as mentioned before, on whether it is a single-task or a parallel run. Once, it is established that a BUFR message is to be processed an appropriate subroutine is called. The choice of which of the subroutines to call is based on the BUFR observation type; they are called the basic observation handling routines. Thus, land-surface data are handled by **LANSUIN**, sea-surface data by **SEASUIN**, upper-air sounding by **UPPAIIN**, satellite soundings by **SATSOIN**, airesps by **AIREPIN**, satobs by **SATOBIN** and **SATAMIN**, scatterometers by **SCATSIN**, ssmis by **SSMISIN** and paobs by **PAOBSIN**. Further stratification within the above mentioned basic observation handling routines is possible, based on the observation subtype. The decision on whether to deepen the processing further is based on how complex an observation type is. For example, in the case of the **AIREPIN** routine there is no extra granulation. On the other hand, in the cases of **UPPAIIN**, **SATSOIN** and **SEASUIN** there is a specialised subroutine for every possible subtype. Thus, the land TEMPs are dealt with by **LANTEIN**, ship TEMPs by **SHPTEIN** and so on. If a CMA report has been created, several arrays/pointers are updated first, and then the CMA report is either written out on a file or added to memory (**ADDCMAR**). The NAMCMA namelist switch **LOC-MAMER** is used for this. **LOCMAMER=.T.** enables the memory-resident CMA, otherwise the CMA is file resident. At this stage, if requested via the **NAMDIA** namelist, both the CMA and the BUFR report can be printed by calling the **RETCMA** and **RETBUFR** subroutines. Since the expanded BUFR message can be compressed before storing it, a new BUFR message is created containing just that report. This is done by calling either the **BUCOMP** or **SPLITCR** subroutines. Which of these is called is controlled by the **NAMBUFR** namelist switch **LBSSPLIT**. Furthermore, the BUFR report from which the CMA report is created can also be either written out on a file or added in the memory (**ADDBUFR**). The **NMKCMA** namelist switch **LIFDBACK** controls whether to write the BUFR report at all, whereas the **NAMBUFR** namelist switch **LOBUFMER** controls whether it would be written out on a file or added to memory. After all reports from BUFR message have been processed the control is handed back to the **SCANBUFR**.

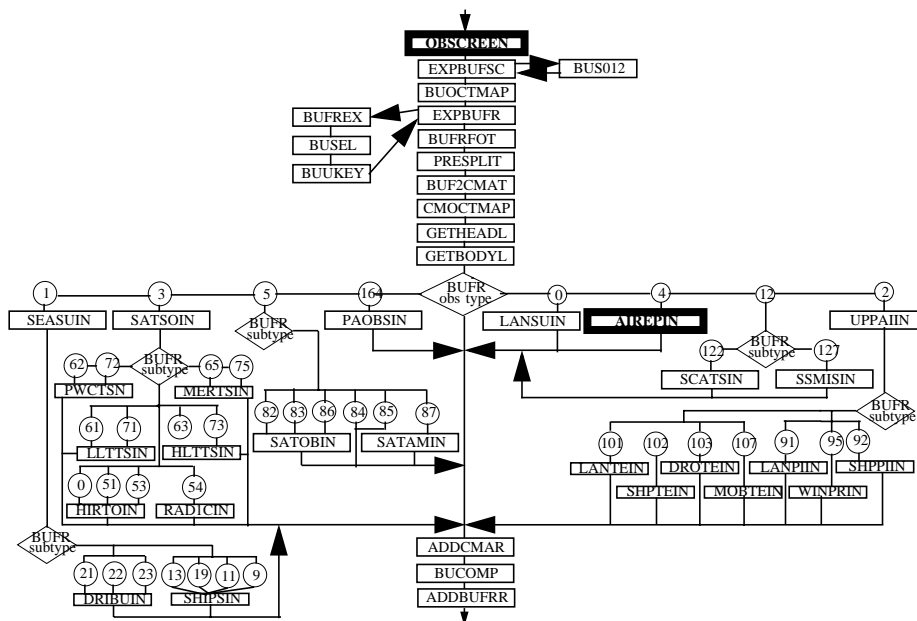

Figure 3.4 Subroutine **OBSCREEN** flow diagram



3.2.5 Basic observation handling routines

As mentioned the above, this group of routines deals essentially with extracting all the required observations' information from a BUFR report, and with converting them into the CMA format/structure. The list of subroutines in this category is:

- **LANSUIN** (land surface data),
- **SEASUIN** (sea surface data):
 - **SHIPSIN** (ship), and
 - **DRIBUIN** (dribu),
- **UPPAIIN** (upper air soundings):
 - **LANTEIN** (land TEMP),
 - **SHPTEIN** (ship TEMP),
 - **DROTEIN** (drop TEMP),
 - **MOBTEIN** (mobile TEMP),
 - **LANPIIN** (land PILOT),
 - **SHPPIIN** (ship PILOT), and
 - **WINPRIN** (wind profiler),
- **SATSOIN** (satellite soundings):
 - **HIRTOIN** (tovs radiances),
 - **LLTTSIN** (low level temperatures),
 - **PWCTSIN** (pwc),
 - **HLTTSIN** (high level temperatures),
 - **MERTSIN** (merged low/high level temperatures and pwc),
 - **RAD1CIN** (level 1C radiances),
- **AIREPIN** (aircraft),
- **SATOBIN** (satob),
- **SATAMIN** (satob),
- **SCATSIN** (scatterometer),
- **SSMISIN** (ssmi), and
- **PAOBSIN** (paob).

Because of the complexity of some observation types, their basic observation handling subroutines are just routines for further branching off, according to the BUFR observation subtype. Thus, the subroutines **SEASUIN**, **UPPAIIN** and **SATSOIN** have an additional stratification.

All the basic observation processing routines, whether invoked directly from the **OBSSCREEN** or from one of the cover routines, have more or less the same strategy, they:

- (a) get basic BUFR report parameters,
- (b) extract BUFR observation variables,
- (c) create a CMA report (the report is created in two phases: header and body creation phases)
- (d) tidy up and hand the control back to the calling routine.

As an example, the flow diagram of **AIREPIN** is shown in [Figs. 3.5](#) and [3.6](#).

Extraction of the basic report parameters, such as the coordinates, date/time and station identification is done by calling subroutine **GETREPP**. The coordinates are checked first to see if they are within physical limits and within the requested geographical area (**REPSEL**). If this type of check is successful, the BUFR date and time parameters are converted to the CMA date and time parameters (**OBSDTTM**), and they are checked to see if they are within chosen data-time window (**TIMDIF**). Furthermore, the BUFR station identification is converted into the CMA station identification (**CHAR2INT**). The next step is to extract quality control flags for the report parameters. Some

BUFR observation types/subtypes are not subjected to the report data-base (RDB) quality-control procedure, and hence do not have accompanying quality control information.

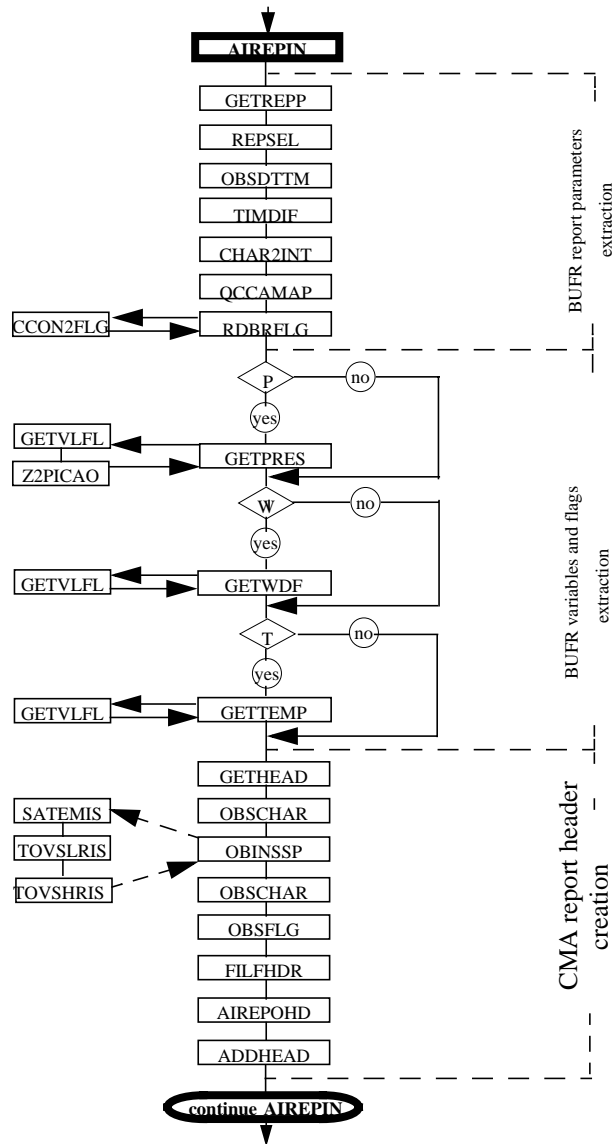

Figure 3.5 Subroutine **AIREPIN** flow diagram

The extraction of the BUFR observation variables is observation-type/subtype dependent and namelist driven. Generally speaking, the conventional observations (SYNOP, AIREP, SATOB, DRIBU, TEMP, PILOT and PAOB) carry similar observed quantities. However, SYNOP may contain much more informations. An important distinction among the conventional observations is whether they are single-level (SYNOP, AIREP, SATOB, DRIBU and PAOB) or multi-level observations (TEMP and PILOT). Effectively, regardless of the observing system, each observed quantity that needs to be extracted is associated with a specialized routine to do the task. Also, in addition to the observed value, they extract, if available, an accompanying RDB quality-control flag. The extraction subroutines which fall in this group are:

- **GETPRES** (pressure),
- **GETWDF** (wind direction and speed),



- **GETTEMP** (temperature),
- **GETPREST** (pressure tendency),
- **GETDEWP** (dew point),
- **GETSNOW** (snow depth),
- **GETRAIN** (rain),
- **GETSHPDS** (ship speed and direction),
- **GETPWC** (pwc),
- **GETRADI** (brightness temperatures),
- **GETSIGMA0** (σ_0).
- etc.

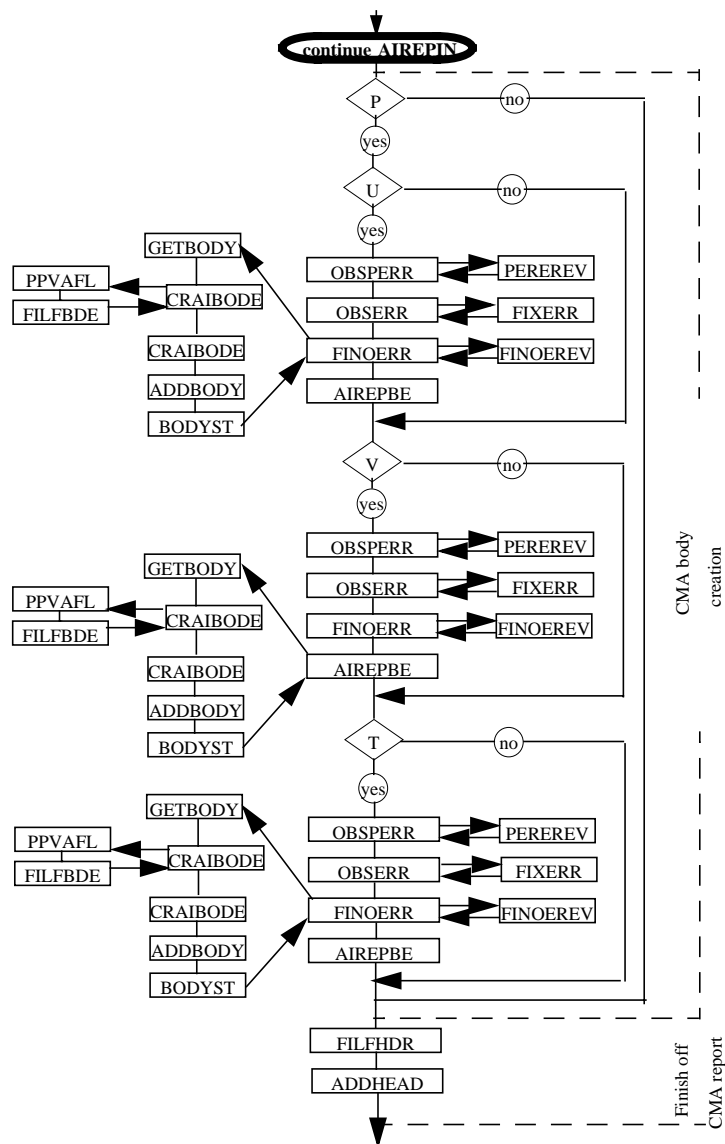

Figure 3.6 Subroutine **AIREPIN** flow diagram (continuation)

All of these routines are just cover routines to prepare for the actual extraction of an observed value and its flag. The actual extraction is done by calling the **GETVLFL** subroutine. The decision on whether or not an observed

quantity is extracted is controlled by the NMMKCMA namelist array NBUFRVSE. This is a three dimensional array of variable number, observation subtype and observation type. The content of this array is either 1 or 0. If the value is 1 the quantity will be extracted.

The next step is to create a preliminary CMA report header. In order to do this, a basic CMA report header is first created by calling the **GETHEAD** subroutine. The idea here is to get a correct CMA-report header structure with the default values set. Secondly, a few report parameters are prepared for storing into the header. These parameters are the observation characteristics (OBSCHAR), observation instrument type (OBINSSP) and the conversion factor for changing coordinates from degrees to radians. Since these parameters belong to a fixed part of a report header, their storing is carried out by calling the **FILFHDR** subroutine. On the other hand, the optional part of the CMA-report header is observation-type dependent, and there is a specialised routine for storing those parameters which are particular to a given observation type. These routines are:

- **SYNOPOHD** (synop),
- **AIREPOHD** (airep),
- **SATOBOHD** (satob),
- **DRIBUOHD** (dribu),
- **TEMPOHD** (temp),
- **PILOTOHD** (pilot),
- **TOVSOHD** (high resolution tovs),
- **ATOVSOHD** (atovs),
- **TOSAHD** (standard TOVS/SATEM),
- **SSMIOHD** (ssmi),
- **PAOBOHD** (paob), and
- **SCATOHD** (scatterometer).

After both the fixed and the optional parts of the CMA-report header have been created and filled up as much as possible at this stage, they are added to the CMA report by calling the **ADDHEAD** subroutine.

Now comes the creation of the CMA-report body. The CMA-report body consists of a number of entries. For every single piece of information, provided it is asked for, an entry is created. The decision on whether or not a piece of information is to be added is controlled by the NMMKCMA namelist array NMKCMVSE. This is a three-dimensional array of variable number, observation code type and observation type. The content of this array is either 1 or 0. If the value is 1 then an entry will be created. It is at this stage that some observed variables are converted to those needed by the analysis. Also, observation errors are assigned at this stage too. The persistence error is assigned by calling the **OBSPERR** subroutine, whereas the prescribed observation error is assigned by calling the **OBSERR** subroutine. The actual observation error (final observation error) is then worked out by calling the **FI-NOERR** subroutine. Once all relevant information is available a body entry is added to a report. Since a body entry is structured in three parts (fixed, run-dependent and observation-dependent parts), there is a cover routine for each observation type which deals with it. The cover routines are:

- **SYNOPBE** (synop),
- **AIREPBE** (airep),
- **SATOBBE** (satob),
- **DRIBUBE** (dribu),
- **TEMPBE** (temp),
- **PILOTBE** (pilot),
- **TOVSBE** (high resolution tovs),
- **ATOVSBE** (atovs),
- **TOSABE** (standard satem/tovs),



- **SSMIBE** (ssmi),
- **PAOBBE** (paob), and
- **SCATBE**.

Firstly, each of these routines calls the **GETBODY** subroutine to get the correct body-entry structure filled up with default values. Then, they call the **CRECBODE** subroutine to finish off the fixed part of the body entry by calling the **FILFBDE** subroutine. It is only after this that they call specialized routines to deal with the observation-dependent part of the body entry. This specialised routines are:

- **CRSYBODE** (synop),
- **CRAIBODE** (airep),
- **CRDRBODE** (dribu),
- **CRSBBODE** (satob),
- **CRTEBODE** (temp),
- **CRPIBODE** (pilot),
- **CRTSBODE** (satem/tovs),
- **CRTOBODE** (tovs radiances),
- **CRATOBODE** (atovs),
- **CRPABODE** (paob), and
- **CRSCBODE** (scatterometer).

Once the body entry has been created it is added to the CMA report by calling **ADDBODY** subroutine. Every time the body entry is created and added to the report several parameters are updated by calling **BODYST** subroutine.

Finally, the CMA-report header (fixed part) is updated with several items of information (e.g. number of body entries) and is replaced back into the CMA report by recalling the **FILFHDR** and **ADDHEAD** subroutines, respectively.





Part I: OBSERVATION PROCESSING**CHAPTER 4 The FEEDBACK task****Table of contents**

- 4.1 Input and output data
- 4.2 Calling tree structure
 - 4.2.1 BUFDLBACK
 - 4.2.2 BFDBAMPP and BFDBASIN
 - 4.2.3 SCANCMA
 - 4.2.4 Basic feed-back handling routines
 - 4.2.5 DATESFD

4.1 INPUT AND OUTPUT DATA

Only two data structures/formats, BUFR and CMA, on both input and output are acceptable. There may be up to seven output BUFR feed-back files. However, at the moment there are only 4 output BUFR feed-back files. Each of them containing: CONVENTIONAL, TOVS, SCATTEROMETER and SSMI observations, respectively. This is to keep the one to one correspondence with the MAKECMA input BUFR files.

4.2 CALLING TREE STRUCTURE

After invoking the OBSPROC, via program **AAOBPPRO**, the subroutine **CNTOBSPR** is called. As explained in [Section 1.5](#), after finding out that the FEEDBACK task is requested, the **CNTOBSPR** branches itself to that section ([Fig. 1.3](#)).

If the FEEDBACK task is to be carried out in a parallel mode, subroutine **PREPROC_MPP_BUFDLBACK** is called first; this routine performs a number of activities. These activities are mainly concerned with preparing for the matchup of the ECMA and the CCMA and for later collection of output BUFR feed-back data. This is achieved by a number of calls to the OBSORT subroutines. The next step is to call master feed-back routine **BUFDLBACK** (more details in the next section).

Once the **BUFDLBACK** has finished and handed back the control to the **CNTOBSPR** the only thing left to do is some tidying up. In the single-task case this simply consists of closing the remaining files. However, in the parallel case subroutine **POSTPROC_MPP_BUFDLBACK** is called. It is via this subroutine, which in turn calls several OBSORT subroutines, that the gathering of the BUFR-feed-back data scattered across PEs is done. The aim of collecting BUFR-feed-back data is to output as many BUFR files as there were in the input when the assimilation cycle started.

4.2.1 BUFDLBACK

BUFDLBACK flow diagram is shown in [Figure 4.1](#). The main purpose of the **BUFDLBACK** subroutine is threefold:

- 1) to initialize various FEEDBACK-task parameters and switches,



4.2.2 BFDBAMPP and BFDBASIN

The idea in both of these routines is to prepare for the actual scanning of the ECMA file, during which all relevant information is taken, and then appended onto the input initial BUFR feed-back (output of the MAKEECMA task). Both subroutines are divided in 5 sections.:

- 1) preparation,
- 2) initialization of input/output files,
- 3) creation of BUFR feed-back,
- 4) finishing off input/output file processing, and
- 5) returning to the caller.

BFDBAMPP subroutine flow diagram is shown in Figure 4.2.

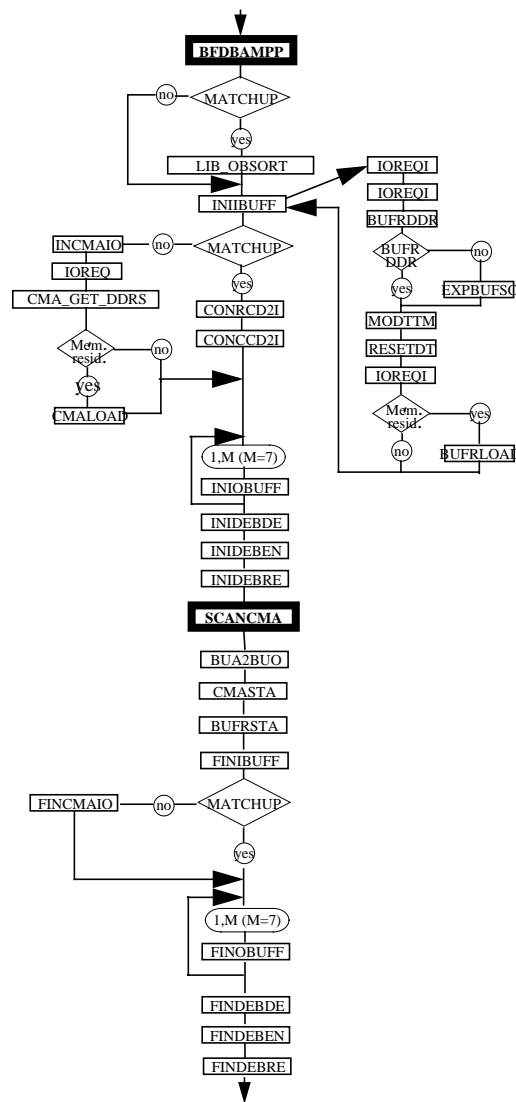

Figure 4.2 Subroutine BFDBAMPP Flow Diagram

The preparation section is appreciably different for parallel and single-task mode. In the single-task case this section is non-existent. However, in the parallel case the provision a match-up of the ECMA and the CCMA is needed;

this is carried out by calling the OBSORT subroutine **LIB_OBSORT**. This is called the **MATCHUP** sub-task. As explained earlier, the **MAKEECMA** task produces the ECMA for the IFS screening run. On the other hand, the IFS screening selects only a subset of data (both in terms of reports and pieces of information) and passes them as CCMA to the IFS minimization run. The CCMA is about 1/10 of the ECMA. Once the analysis has finished there is a need to update the original ECMA with all relevant information stored in the CCMA. This update is carried out by calling the **LIB_OBSORT** with the match-up options chosen.

In the second step (input/output file initialization) the same subroutines as in the **MAKEECMA** task are called. Thus, BUFR input/output files are initialized by the **INIIBUFF** and **INIOBUFF** subroutines, the CMA file is opened up (if at all) by **INICMAIO** and diagnostic/debugging files are initialized by calling **INIDEBDE**, **INIDEBEN** and **INIDEBRE**.

Third step is to perform the actual feed-back. In order to do this the control is handed down to the main data-scanning subroutine **SCANCMA** (more details in the next subsection). Upon its completion the control is returned so that the diagnostics print-out (**CAMSTA** and **BUFRSTA**) and the closing of files can take place.

It is worth explaining here in more detail what is happening with CMA data at this stage, in relation whether it is a parallel or single-task run. In the single-task case the CMA file is initialized by calling the **INICMAIO** subroutine, which in turn may call the **CMALOAD** subroutine if the CMA data are to be memory resident (the NAMCMA namelist switch LICMAMER=.T.). However, in a parallel run with the **MATCHUP** option (LMATCHUP=.T.) the CMA files (ECMA and CCMA) would have already been read by the **MATCHUP** sub-task and the ECMA updated. Within the **MATCHUP** context the updated ECMA could be written out and/or passed down, as an internal array, for further use. The NAMRUN namelist switch LFWRICMA controls this option. If the ECMA was written out, its initialization would be very similar as the one in the single-task case. On the other hand, if it is passed as an internal array, only the ECMA DDRs are handled explicitly at this stage. There is another NAMRUN namelist switch LFREACMA, which can be used to read the updated ECMA rather than to use internally available one.

4.2.3 **SCANCMA**

The aim of this subroutine, which flow diagram is shown in [Figure 4.3](#) and [Figure 4.4](#), is to loop over the updated ECMA and the initial BUFR feed-back reports (with one to one correspondence) and to pass from CMA all data assimilation observation related informations to BUFR. **SCANCMA** is divided into 6 logical sections:

- 1) The initial pre-set is carried out. This consists of a number of steps. For example, it prepares for a possible BUFR feed-back compression, prints some messages, initializes some local variables etc.. Finally, a loop over CMA time slots is started.
- 2) A loop over the CMA and BUFR reports is started. A pair of CMA and BUFR reports are then read in. Regardless whether the ECMA and/or BUFR may be file- or memory-resident, reports are made available by calling the **GETICMAR** (to get a CMA report) and **GETIBUFR** (to get a BUFR report) subroutines. These reports are then checked to see if they correspond to each other.
- 3) After establishing the CMA-BUFR correspondence, some input BUFR-report information is saved, since they are needed later for BUFR encoding.
- 4) Depending which CMA observation type is considered, **SCANCMA** branches off to one of the basic feed-back observation-handling routines. It is in these routines, or in those that they may be calling, that the actual feed-back is done (more details in the next subsection). These routines are:
 - **SYNOPOUT** (SYNOP);
 - **AIREPOUT** (AIREP);
 - **SATOBOUT** (SATOB);
 - **DRIBUOUT** (DRIBU);
 - **TEMPOUT** (TEMP);



- **PILOTOUT** (PILOT);
- **HRTOVOUT** (high resolution TOVS);
- **RADICOUT** (level 1C);
- **TOSAOUT** (standard SATEM/TOVS);
- **SSMISOUT** (SSMI);
- **PAOBOUT** (POAB); and
- **SCATSOUT** (SCATTEROMETER).

There is one routine for each CMA observation type, as their names imply, (with the exception of SATEMs).

- 5) After the control is returned from one of the basic feed-back routines it is checked whether the report is for BUFR compression. If so, subroutine **PREPLCOM** is called to add it onto a temporary storage which, when full, is passed to subroutine **ENCPFM** for encoding. **ENCPFM** is just a cover routine with a further call to encode the compressed BUFR data. At the present time, BUFR compression is applied for TOVS, SSMI, ATOVS and SCATTEROMETER data only. A BUFR report not meant to be compressed is encoded straight away using the BUFR encoder routine **ENCBUFR**. The encoded BUFR message is then added either onto a file or to an array, depending on whether the output feed-back BUFR is file- or memory-resident. This is done by calling the subroutine **ADDBUFR**. At this stage a few diagnostics parameters/arrays are updated and, if required, reports printed.
- 6) Before finishing the processing in **SCANCMA**, the temporary storage (for the BUFR feed-back reports that are meant to be compressed) is checked again and any remaining reports compressed and encoded.

BUFR feed-back compression is controlled by a number of switches and parameters. There are 4 switches and 12 adjustable parameters; 3 for TOVS, 3 for SSMI, 3 for ATOVS and 3 for SCATTEROMETER data. Switches are held in the NAMFDBAC namelist, whereas parameters are held in the NAMBUFR namelist. These switches are: LBUFRCOM, LTOVSCOM, LSSMICOM and LSCATCOM. LBUFRCOM is the master compression switch, whereas the others control compression of TOVS/ATOVS, SSMI and SCATTEROMETER data. The idea with the adjustable parameters is to be able to adjust them from time to time. They control: number of elements in the BUFR report, the number of reports (packet size) to form one BUFR message and the number of platforms (station id's) to be compressed. The TOVS compression-related parameters are NPTSELM, NPTSPKT and NPTSPFM, whereas the ATOVS compression-related parameters are NPATSELM, NPATSPKT and NPATSPFM. The SSMI parameters are: NPSMELM, NPSMPKT and NPSMPFM and the SCATTEROMETER parameters are NPSCELM, NPSCP-KT and NPSCP-FM.

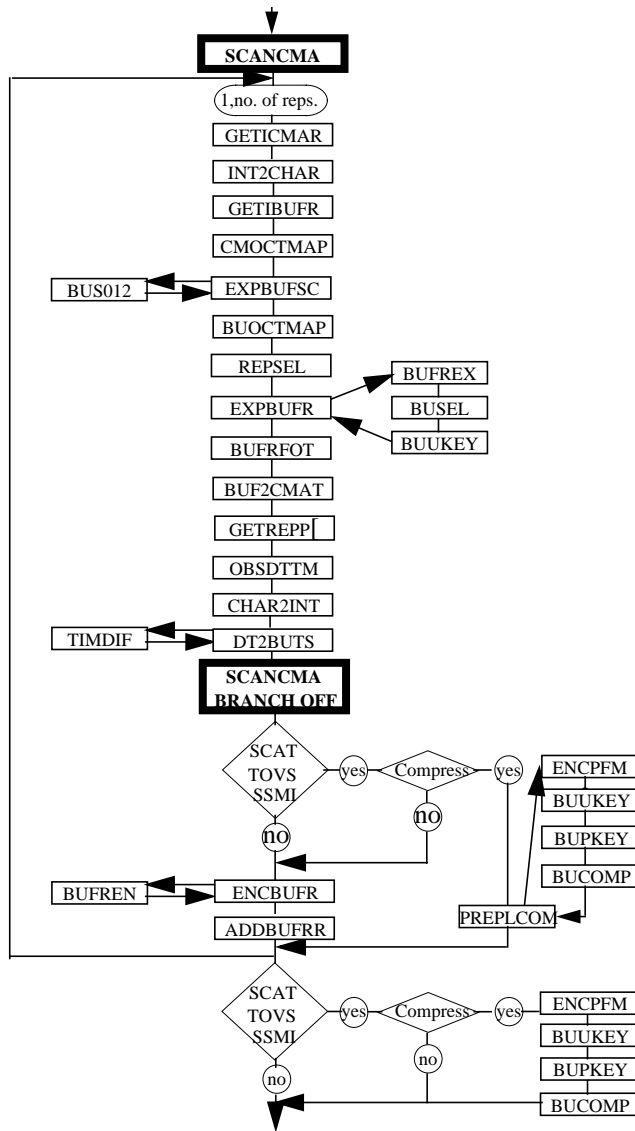
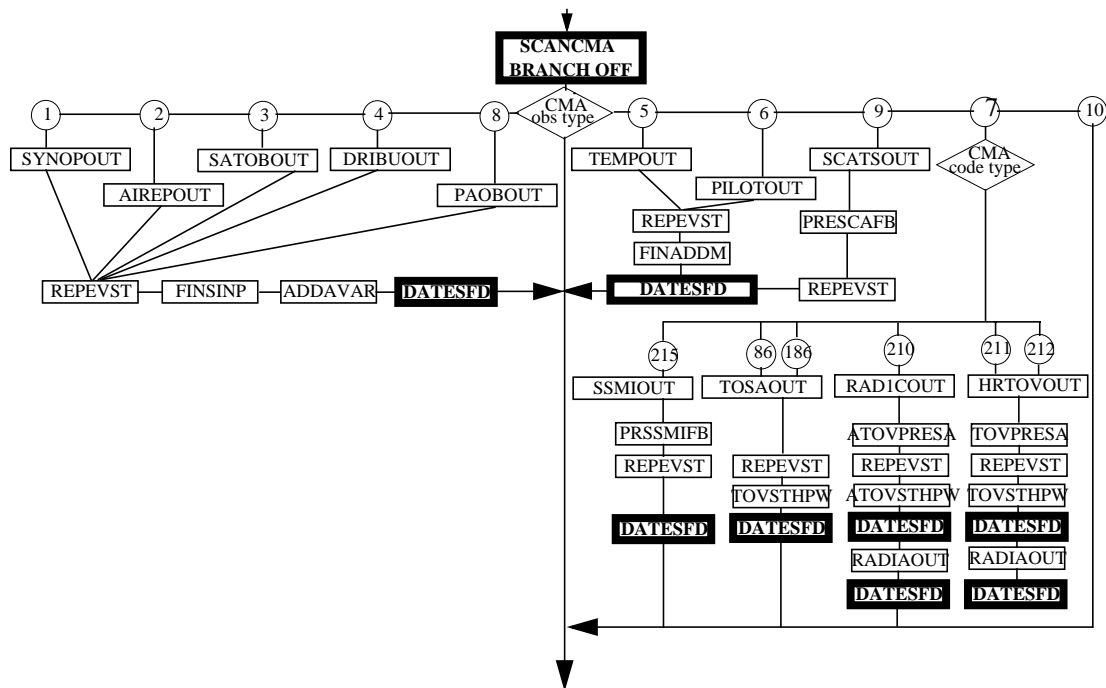

Figure 4.3 Subroutine SCANCMA Flow Diagram

Figure 4.4 Subroutine **SCANCMA** BUFR Observation Type Branch Off Flow Diagram

4.2.4 Basic feed-back handling routines

Basic feed-back handling routines, listed in the previous sub-section more or less have a very similar strategy (see Figure 4.4).

After some initial pre-set, information related to a particular report as a whole is searched for, and the feed-back appended onto to a BUFR report by calling the **REPEVST** subroutine. The report feed-back information comprises:

- (a) flags;
- (b) events 1;
- (c) blacklist events;
- (d) events 2; and
- (e) status.

Whether they are fed back at all is controlled by the master switch **LFBREVST** from the **NAMFDBAC** namelist. Feed-back of reports events no 1, blacklist events, events no. 2 and status is controlled by further four **NAMFDBAC** namelist switches: **LFBREVE1**, **LFBRBLEV**, **LFBREVE2** and **LFBRSTAT**, respectively.

However, in the case of **TOVS**, **ATOVS**, **SCATTEROMETER** and **SSMI** observations additional subroutines **TOVSPRES**, **ATOVSPRES**, **PRESCAFB** and **PRSSMIFB** are called first at this stage. **TOVSPRES**, **ATOVSPRES** and **PRSSMIFB** deal with feeding back the 'pre-SAT'/'pre-SSMI' and 1D VAR related information stored mostly in the optional part of the **TOVS**, **ATOVS** and **SSMI** CMA-report header. This is controlled by **LPRESAFB**, **LPREASFB** and **LPRESSFB** switches from the **NAMFDBAC** namelist. In the case of **SCATTEROMETER** data it is a different set of informations to deal with and switch **LPRESCFB** is used for that.

The next step is to feed-back analysis variables. Depending on observation type, a different subroutine may be called. In the case of the conventional single-level reports **FINSINP** is called, whereas for the conventional multi-

level reports **FINADDM** is called. Thus, **SYNOPOUT**, **AIREPOUT**, **SATOBOUT**, **DRIBUOUT** and **PAOBOUT** would be calling **FINSINP**, whereas **TEMPOUT** and **PILOTOUT** would be calling **FINADDM**. However, in the case of high resolution TOVS (handling routine **TOSAOUT**), **ATOV**S or standard **SATEM/TOVS** (handling routine **TOSAOUT**) further granulation takes place by calling the **TOVSTHPW**, **ATOVSTHPW** and **RADIAOUT** subroutines. In the case of **SCATTEROMETER** and **SSMI** reports, the feeding back of the analysis variables is done in-line; hence, **SSMISOUT** and **SCATSOUT** have no further calls.

Finally, in the last step the analysis variables' flags, events, status, error statistics, departures, etc. are fed back. This is achieved via the **DATESFD** subroutine call (see next subsection), after which the control is handed back to the calling subroutine.

4.2.5 DATESFD

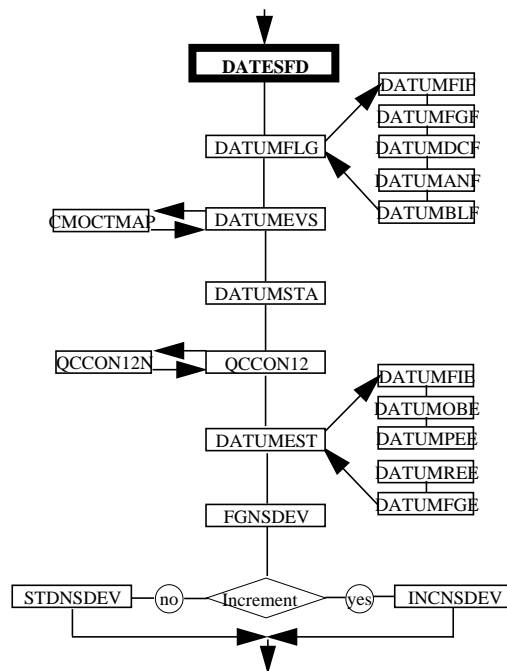

Figure 4.5 Subroutine **DATESFD** Flow Diagram

This subroutine, for which the flow diagram is shown in [Figure 4.5](#), deals with feeding back several different types of informations:

- (a) analysis quality control flags are fed back by calling the worker **DATUMFLG** subroutine,
- (b) analysis variables' events are fed back by calling the **DATUMEVS** subroutine,
- (c) analysis variables' status is dealt with by calling the **DATUMSTA** subroutine,
- (d) analysis variables' quality control constants are fed back via a call to the **QCCON12** subroutine,
- (e) analysis variable's error statistics are dealt with by calling the **DATUMEST** subroutine,
- (f) analysis variables' difference statistics (departures) are handled by calling a few extra routines
 - first-guess departures are handled by the **FGNSDEV** subroutine,
 - depending on whether it is a feed-back for the incremental or for the standard variational run, the subroutine **INCNSDEV** or **STDNSDEV** may be called, respectively.

Furthermore, there are a number of switches which control what flags, events departures etc. are fed back. All these switches are held in the **NAMFDBAC** namelist.



The feed-back of analysis quality-control flags is controlled by six switches. The master switch is LFBDFLAG and it controls whether to feed back the flags at all. The other five switches control the feed-back of a particular set of flags. These sets of flags are the first-guess, the analysis, the blacklist, the departure and the final-check flags. Their corresponding switches are LFBDFGFL, LFB DANFL, LFBDBLFL, LFB DDEFL and LFBDFIFL.

The feed-back of analysis variables' events and status is controlled by five switches; these are LFBDEVST, LFBDEVE1, LFBDBLEV, LFBDEVE2, LFB DSTAT. The master switch is LFBDEVST, whereas the others control the feed-back of the variables' events no. 1, the blacklist events, the variables' events no. 2 and the variables' status, respectively.

For the analysis variables' quality-control constants the feed-back is controlled by LFB DQCCO switch.

When it comes to feeding back the analysis variables' error statistics, five switches are used. Again, there is a master switch (LFB DERRS) and a switch for each type of observation-error statistics. Thus, the feed-back of the final, prescribed, persistence, representativeness and first-guess errors is controlled by LFBDFIER, LFBDOBER, LFB DPEER and LFB DREER switches, respectively.

The feed-back of departures is handled by nine switches. However, what departures may be available depends on whether it is an incremental or a non-incremental variational analysis. There is only one master switch (LFB DDEPT), regardless of the variational analysis type. Both types have first-guess and analysis departures, and they are handled by the LFBDFGDE and LFB DANDE switches, respectively. Additionally, the incremental variational analysis has four 'update' departures: very initial; initial hi-resolution; initial low-resolution; and final low-resolution departures, and they are controlled by LFB DUIDE, LFB DUHDE, LFB DULID, LFB DULFD, respectively. Furthermore, in both the incremental and the standard cases some additional departures (if present) may be fed back too. These additional departures are those which may have been saved at various stages in the minimization process and their feed-back is controlled by LFB DSIDE switch.





Part I: OBSERVATION PROCESSING**CHAPTER 5 The **TOOLS** task****Table of contents**

5.1 Basic principles

5.2 CMA tools

5.2.1 IRETCMA (CMA print tool)

5.2.2 Convergence test

5.2.3 ICONVERG (CMA convergence test tool)

5.3 BUFR tools

5.3.1 IRETBUFR (BUFR print tool)

5.3.2 ISPLITR (BUFR split tool)

5.3.3 DEBUGBDE (BUFR decode debug tool)

5.3.4 DEBUGBEN (BUFR encode debug tool)

5.4 Simulated-observation tools

5.1 BASIC PRINCIPLES

The main purpose of this task is to perform various observation-processing-related diagnostics/debugging activities outside the data-assimilation cycle. By having it as a part of the OBSPROC, one makes use of the existing code structures already developed for two main tasks, the **MAKECMA** and the **FEEDBACK**.

There are three types of activities (sub-tasks) within the **TOOLS** task. These sub-tasks are:

- CMA tools;
- BUFR tools; and
- SIMULATED-observations tools.

As their names imply they are related to the specific data structures.

The **TOOLS** task, as with the other two, is invoked by starting the OBSPROC, via program **AAOBPPRO**. The subroutine **CNTOBSPR** is called next which in turn, after finding out that the **TOOLS** task is to be carried out, branches itself and calls the **TOOLS** subroutine (see [Fig. 1.2](#) and [Fig. 1.3](#) of [Chapter 1 ‘Non-IFS observation processing \(OBSPROC\): General overview’](#)).

Once in the **TOOLS** subroutine (see [Fig. 5.1](#)) a partial pre-set is carried out first. This pre-set includes setting up the definitions of:

- numerical limits (SULIM),
- variables’ numbers (SUVNMB),
- level/layers structure (SULEVLAY),
- CMA observation and code types (SUCMOCTP),
- BUFR observation types and subtypes (SUBUOCTP),

- observation events (SUEVENTS),
- observation flags (SUFLTXT),
- various observation processing codes (SUCODES),
- BUFR data structure and format (SETBUFR),
- SIMULATED observation structure and format (SUSIM),
- CMA data structure and format (SUCMA),

The next step is to print the chosen run set-up by calling **PREAMB** subroutine. Then, depending on the status of the NAMDIA namelist switches LCMATOOL, LBUFTOOL and LSIMTOOL, it will branch itself off to an appropriate section and start the sub-task. The CMA tool sub-task is invoked if LCMATOOL=.T., whereas the BUFR tool and the SIMULATED-observations tool are started if LBUFTOOL=.T. or LSIMTOOL=.T..

Before either of these two routines is called, the CMA file is initialized (INICMAIO) and the CMA DDRs read. As the read-in DDRs are reals at this stage, their integer and character sections are worked out by calling the **CONRCD2I** and **CONRCD2C** subroutines, respectively. Furthermore, at this stage, if the NAMDIA namelist switches LOPRCMD=.T., the CMA DDRs will be printed out (**PRTDDR**). The NAMDIA namelist switches the LOPRCMA and LCONVER control if either the **IRETCMA** or **ICONVERG** subroutine is called next. **IRETCMA** is the master subroutine for printing the CMA reports, whereas **ICONVERG** is the master routine for the convergence test. After returning from either of these two routines, some diagnostic print takes place by calling either the **CMATA** or **CONVSTA** subroutine. The last step is to close the input CMA file (**FINCMAIO**).

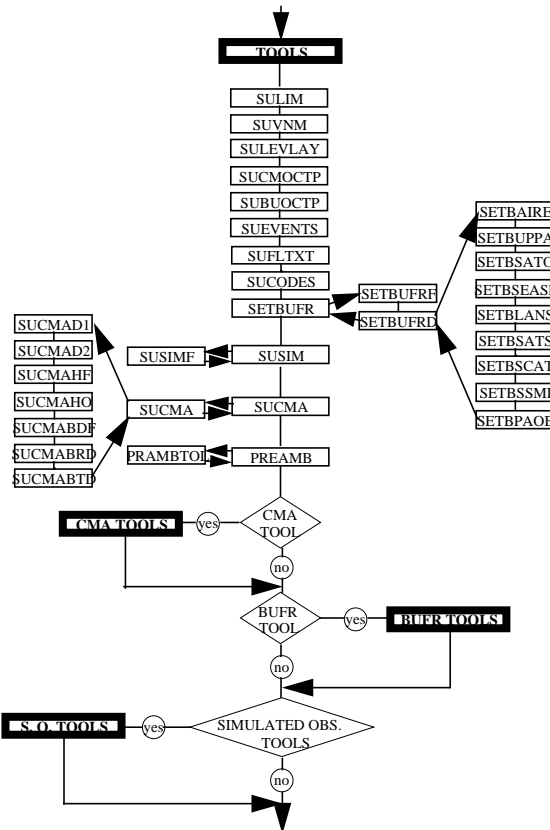

Figure 5.1 Subroutine **TOOLS** flow diagram

5.2 CMA TOOLS

At the moment there are two kinds of activities in the CMA tools (see Fig. 5.2):

- CMA report(s) print tool, and
- CMA convergence-test tool

Which of these two activities will be carried out depends on the status of the NAMDIA namelist switches LOPRCMA and LCONVER. If LOPRCMA=.T. the CMA print tool is started. However, if LCONVER=.T. the CMA convergence-test tool is invoked instead.

The idea of the CMA print tool is that, for an already existing CMA file, one can print CMA report(s) for a given

- geographical area, and/or
- observation type or code type.

On the other hand, the idea of the CMA convergence-test tool is to scan the CMA observations used in the minimization and perform some diagnostic calculations by which one can, perhaps, establish whether there was a convergence problem.

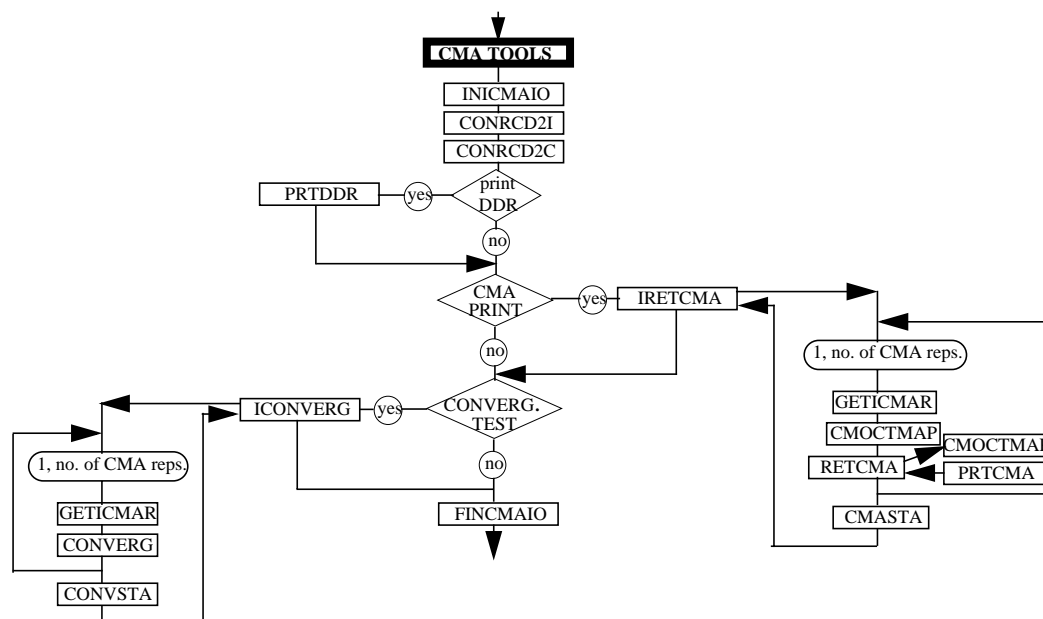

Figure 5.2 Subroutine **TOOLS** (CMA TOOLS) branch-off flow diagram

5.2.1 **IRETCMA** (CMA print tool)

The main purpose of this subroutine (see Fig. 5.2) is to loop over the CMA reports, and for each of them to call the worker routine **RETCMA**. Each CMA report is fetched by calling the **GETICMAR** subroutine. After getting hold of a report, CMA observation type and code type are found and mapped into the OBSPROC internal CMA sequence numbers by calling **CMOCTMAP**. Once in the **RETCMA** subroutine, several parameters are extracted from a report and checked against the request. Extracted parameters are: observation type, observation code type, latitude, longitude and observation sequence number. There are three layers of checking before it is decided whether to print a report. First, observation sequence number is checked against the requested one (the NAMDIA namelist parameter NOBNUM), and if matched no further checking is carried out and CMA report is printed. Next

step is to check the observation type/code type against the NAMDIA namelist parameter NOCTRQ. However, if NOCTRQ is set to 999, no check on the observation /code type is performed. Finally, the observation coordinates are checked against the NAMDIA namelist parameters RDINLAT, RDISLAT, RDIWLON and RDIELON. These parameters are the north and south latitudes, and the west and east longitudes, of a requested geographical area. Upon successful completion of all these checks, the CMA report is printed by calling the **PRTCMA** subroutine.

5.2.2 Convergence test

A simple diagnostic of the incremental variational analysis can be found from jumps of J_o between the low and high resolutions: the smaller jumps, the better it is. The important assumption in the incremental technique is that a change in the low resolution should correspond to a similar change at high resolution (when the low resolution is in some sense added to the high resolution fields). Since J_b and J_c are identical at both resolutions the convergence of the high resolution cost function can completely be monitored using the observation departures which are available from CMA reports. Let us call H_h and H_l forward operators at high and low resolution, x_{begin} and x_{end} the initial model state at the beginning and at the end of a given inner loop at a relevant resolution. What we want to compare is:

$$h = H_h(x_{end}) - H_h(x_{begin})$$

and

$$l = H_l(x_{end}) - H_l(x_{begin})$$

by looking at the ratio h/l . In practice h is found by subtracting the initial from the final departure at the high resolution, whereas l is found by subtracting the initial from the final departure at the low resolution.

This tool, after finding h and l for each piece of information used in the minimization, either performs convergence test (option 1) or outputs them together with a few other informations for further use (option 2).

When performing the convergence test, first the size of the change is established. This is done by comparing l with the observation error (σ_o). If $l < \alpha\sigma_o$ (α is constant currently set to 0.1) we recognise three cases:

- 1) $h < 2\alpha\sigma_o$; no conclusion (the ratio is undefined)
- 2) $h > 2\alpha\sigma_o$; excessive reaction
- 3) $h < -2\alpha\sigma_o$; negative reaction

whereas, if $l > \alpha\sigma_o$ we recognise six cases:

- 1) $h/l > 2$; excessive reaction
- 2) $1 + \beta < h/l < 2$; overreaction
- 3) $|h/l| < 2$: OK
- 4) $\gamma < h/l < 1 - \beta$; underreaction
- 5) $|h/l| < \gamma$; no reaction
- 6) $h/l < -\gamma$; negative reaction

β and γ are also constants and currently set at 0.1.

5.2.3 **ICONVERG** (CMA convergence test tool)

There are two options here:

- 1) to perform convergency test, or



- 2) to extract and process the information available from the CMA, and then to output them for further use.

As in the CMA print tool case the main purpose of the **ICONVERG** subroutine is to perform some preparation before calling its worker routine **CONVERG** (see Fig. 5.2). This preparation consists of initializing a few arrays and getting hold of a CMA report (by calling the **GETICMAR** subroutine). Once a report is passed to the **CONVERG** subroutine it is first subjected to the same sort of checking as in the CMA print tool to find out if the report is to be considered. Checks of a loop over a number of updates and a loop over report's body entries are started next. It is within these loops that h and l (as referred to in the previous subsection) are calculated.

There are two different types of outputs. The NAMDIA namelist switch **LFBDVOUT** is used to control them. If **LFBDVOUT=.T.** the type of output is such to give enough information for further processing, and they are:

- report name, coordinates
- variable name, level, observed value, observation error, h and l

In the case of **LFBDVOUT=.F.** (standard output) there are two options. These two options are controlled by the NAMDIA namelist switch **LANYPR**. If **LANYPR=.T.** a similar, but much more detailed compared with the previous one, print is produced. On the other hand, if **LANYPR=.F.** a form of convergence test (see 5.2.2) is performed first and then the result printed out.

5.3 BUFR TOOLS

There are four different BUFR tools (see Fig. 5.3):

- 1) BUFR print tool,
- 2) BUFR split tool,
- 3) BUFR decode debug tool, and
- 4) BUFR encode debug tool.

The idea underpinning the BUFR print tool is very similar to that of the CMA print tool, that is to print BUFR report(s) for a given:

- (a) geographical area, and/or
- (b) observation type/subtype.

The master routine for this is **IRETBUFR**.

The purpose of the BUFR split tool is to break down the compressed BUFR messages into single ones. The master BUFR split tool subroutine is **ISPLITR**.

The idea behind the BUFR debug (decode and encode) tool is that when there is a problem in either **MAKECMA** or **FEEDBACK** task, when either decoding or encoding a BUFR message, the message is written out on a special file that can then be used as an input to one of these tools, with a view to performing in-depth analysis what went wrong. The master BUFR debugging routines are: **DEBUGBDE** (decode tool) and **DEBUGBEN** (encode tool).

As said earlier the NAMTOOLS namelist switch **LBUFTOOL(=.T.)** forces subroutine **TOOLS** to branch off to BUFR tools section. Once there, some aspects of the BUFR software are initialized via a call to the **BUPRQ** subroutine. Now, depending on the status of the NAMTOOL namelist switches **LOPRBUFR**, **LSPLITR**, **LBUGDE**, **LBUGRE** and **LBUGEN**, the **TOOLS** subroutine branches itself off once more to an appropriate section. **LOPRBUFR** and **LSPLITR** are the BUFR print and BUFR split-tools master switches, respectively. **LBUGDE**, **LBUGRE** or **LBUGEN** are master switches for the BUFR decode and the BUFR encode–debug tools.

If either the BUFR print or split tool is chosen, for each input BUFR file the subroutine **INIIBUFF** is called to in-

italize it. In addition, the BUFR debug files are initialized by calling the **INIDEBDE**, **INIDEBEN** and **INIDEBRE** subroutines. If **LOPRBUFR=.T.** some pointers/arrays are initialized, and **IRETBUFR** is called; upon completion some observation processing statistics are printed by calling **BUFRSTA** subroutine. If **LSPLITR=.T.** then, in addition to previous case, the output BUFR file is initialized by calling the **INIOBUFF** subroutine and then subroutine **ISPLITR** is called. Once **ISPLITR** has finished, the BUFR output file creation is completed by calling the **BUA2BUO** subroutine, some BUFR split-tool statistics are printed by calling **BUFRSTA** subroutine, and the output BUFR file is closed by calling the **FINOBUFF** subroutine. In either case, each input BUFR file is finally closed by calling the **FINIBUFF** subroutine, whereas the BUFR debug files are closed by calling the **FINDEBDE**, **FINDEBEN** and **FINDEBRE** subroutines.

If **LBUGDE=.T.** or **LBUGRE=.T.**, the BUFR decode–debug tool is invoked. Before calling the **DEBUGBDE** subroutine, the input/output files are first initialized by calling the **INIDEBDE** and **INIDEBRE** subroutines. Once **DEBUGBDE** has finished the input/output files are closed by calling **FINDEBDE** and **FINDEBRE**.

There are two main types of possible problems when encoding BUFR message. The first type occurs when encoding the BUFR key and second when encoding the BUFR message itself. If **LBUGEN=.T.**, the BUFR encode–debug tool is started. If the NAMTOOL namelist switch **LBUGKY=.T.**, the debugging of BUFR key encoding is started. Otherwise the debugging of BUFR message encoding is invoked.

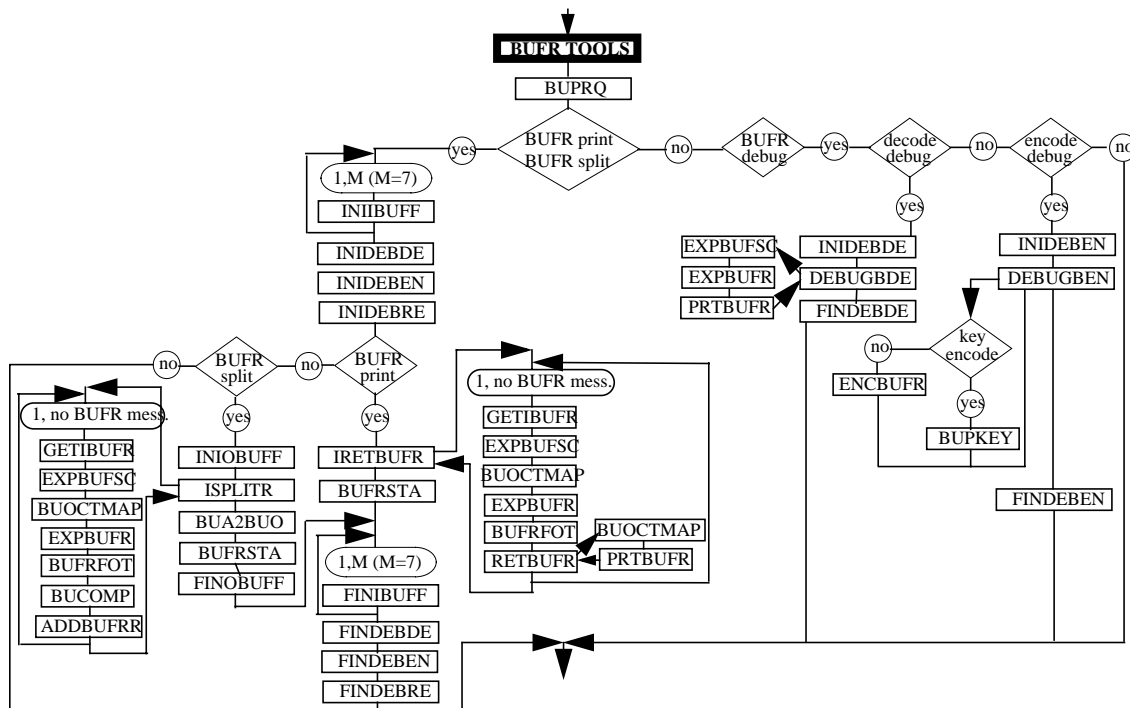

Figure 5.3 Subroutine **TOOLS** (BUFR **TOOLS**) branch-off flow diagram

5.3.1 **IRETBUFR** (BUFR print tool)

The main purpose of this subroutine is to loop over the BUFR reports and, for each of them, to call the worker-routine **RETBUFR** (see Fig. 5.3). Each BUFR report is fetched by calling the **GETIBUFR** subroutine. Once a report is available, several things are done in preparation for calling **RETBUFR**. This preparation includes expanding the BUFR sections (**EXPBUFSC**) and the BUFR message (**EXPBUFR**), checking the BUFR format (**BUFRFOT**) and mapping the BUFR observation type and subtype onto the **OBSPROC** internal sequence numbers (**BUOCT-**



MAP). Once in the **RETBURF** subroutine, several parameters are extracted from a report and checked against the request. Extracted parameters are: observation type, observation subtype, latitude and longitude. There are three layers of checking before it is decided whether or not to print a report. Observation type and subtype are checked against the NAMDIA namelist parameter **NOCTRQ**. However, if **NOCTRQ** is set to 999 no check on observation type and subtype is performed. The next observation coordinates are checked against the NAMDIA namelist parameters **RDINLAT**, **RDISLAT**, **RDIWLN** and **RDIELON**. These parameters have the same meaning as in the CMA print tool. Upon a successful completion of these checks, the BUFR report is printed by calling the **PRTBUFR** subroutine.

5.3.2 **ISPLITR** (BUFR split tool)

The idea here is to loop over the BUFR messages and, for the compressed (multiple BUFR reports in one message) ones, to do the decompression (one BUFR report per BUFR message). **ISPLITR**, after some preparations, calls either its own worker routine **SPLITCR** or BUFR software provided routine **BUCOMP** (see Fig. 5.3); the NAMBUFR namelist switch **LBSSPLIT** controls which of these two will be used. If **LBSSPLIT=.T.** the BUFR software routine is used. However, when using **SPLITCR** (**LBSSPLIT=.F.**) an extra call to the **PRESPLIT** subroutine is needed. Regardless of which of these two worker routines is eventually called, the prior preparation is the same. This includes various pre-sets, the decoding of the BUFR sections, message, etc.

5.3.3 **DEBUGBDE** (BUFR decode debug tool)

As mentioned before, if there is a problem when decoding BUFR messages in one of the two main tasks, they are written out onto a special file. Then the decoding is retried away from the main tasks by using this tool. The idea here is to be able to establish what really went wrong.

5.3.4 **DEBUGBEN** (BUFR encode debug tool)

Two main tasks also encode BUFR messages and, if there is a problem, all relevant information is written out onto a special file. This information is then used by this tool to try to perform in-depth analysis what was wrong. This tool deals with two types of encoding problem: BUFR message-encoding problems and BUFR key-encoding problem. The NAMTOOL namelist switch **LBUGKY** controls which of these two activities is to be carried out. If **LBUGKY=.T.**, the BUFR key-encoding debugging is invoked.

5.4 SIMULATED-OBSERVATION TOOLS

There is only one activity in the simulated-observations tool (see Fig. 5.4). Data assimilation has had its standard simulated-observation structure/format defined for quite some time. This structure/format is still acceptable as an input-data format/structure by **OBSPROC**, or rather **MAKECMA**. However, there are two shortcomings when using this structure/format as direct input to create the CMA data, and subsequently to use them in the analysis. Firstly, it cannot be used in the context of the parallel **MAKECMA** version, and secondly there is no feedback. In order to overcome these two deficiencies, a view taken was that we should keep the well-established (standard) simulated-observation structure/format, but to convert it into the BUFR structure/format. By using this approach, both problems are solved in one go. Also, a special BUFR software utility was designed to carry out this conversion.

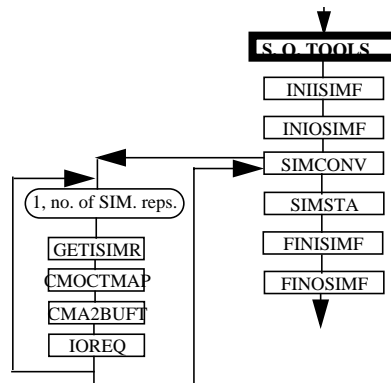

Figure 5.4 Subroutine **TOOLS** (simulated-observation tools) branch-off flow diagram

However, for BUFR software it was rather difficult to use the existing standard simulated-observations structure/format directly. This problem is solved by regarding the simulated-observations tool as a part of the OBSPROC's tools task, the purpose of which is to convert the standard simulated-observation structure/format into a 'converted' simulated-observation structure/format that is acceptable to the BUFR software utility.

The NAMTOOL namelist switches, `LSIMTOOL=.T.` and `LSIMCONV=.T.`, force the **TOOLS** subroutine to branch off to the simulated-observation-tool section. Once in that section, the input simulated-observations file is first initialized via a call to the **INIISIMF** subroutine. Also, the output converted simulated-observation file is initialized by calling the **INIOSIMF** subroutine. The actual conversion is carried out by calling subroutine **SIMCONV**. After the conversion is complete, some diagnostics are printed out by calling the **SIMSTA** subroutine, and then both the input and the output files are closed by calling **FINISIMF** and **FINOSIMF**, respectively.



Part I: OBSERVATION PROCESSING

**CHAPTER 6 Central-memory array (CMA) structure/
format**

Table of contents

- 6.1 Computer representation and CMA file structure
- 6.2 CMA DDR format
 - 6.2.1 DDR1 Format
 - 6.2.2 DDR2 Format
- 6.3 Observation-report format
 - 6.3.1 Observation Report Header Format
 - 6.3.2 Observation-report-body entry format
- 6.4 Packing description sections (PDS)
 - 6.4.1 PDS time
 - 6.4.2 PDS date
 - 6.4.3 PDS-model-profile indicator bit map
 - 6.4.4 PDS bit map, indicating additional departures saved
 - 6.4.5 PDS-observation characteristics
 - 6.4.6 PDS-report flags
 - 6.4.7 PDS Reports Status
 - 6.4.8 PDS-report events, Part 1
 - 6.4.9 PDS-report blacklist events
 - 6.4.10 PDS instrument specification
 - 6.4.11 PDS-report events, part 2
 - 6.4.12 PDS scatterometer-product flags
 - 6.4.13 PDS observation flags, RDB
 - 6.4.14 PDS analysis-datum flags
 - 6.4.15 PDS observation-datum status
 - 6.4.16 PDS data events, Part 1
 - 6.4.17 PDS data-blacklist events
 - 6.4.18 PDS data events, Part 2
 - 6.4.19 Level-identifier bit map

6.4.20 SYNOP pressure-code bit map

6.5 Code-description sections (CDS)

6.5.1 CDS type of section

6.5.2 CDS Type of Variational Analysis

6.5.3 CDS IFS configuration number

6.5.4 CDS satellite-identity codes

6.5.5 CDS observation-type and observation-code-type codes

6.5.6 CDS variable-number codes

6.5.7 CDS vertical-coordinate type

6.5.8 CDS instrument-type codes

6.5.9 CDS 5.5.14 retrieval codes

6.5.10 CDS geographical-area codes

6.5.11 CDS SATOB I1 codes, name of country

6.5.12 CDS SATOB I2I2 codes, satellite-indicator figure

6.5.13 CDS SATEM TOVS A, B, C, V, W, X, Y codes

6.5.14 1D-VAR SSM/I surface-type quality control

6.5.15 1D-VAR failure indicator

6.1 COMPUTER REPRESENTATION AND CMA FILE STRUCTURE

All of the information in the CMA file is FORTRAN 64 bits real, in IEEE formats. Some of the word positions contains integer information, but they are stored as their real equivalents. Characters are stored as real equivalents of their Holleriths values. When it is mentioned later on in this chapter that some of the information in the CMA is of the type integer or character, it is important to keep in mind that this means that the information is *logically* of the type integer or character. *Physically* all of the information is 64 bits real.

The file structure is a simple bit stream. It is comprised of the following basic record units:

- data-description record 1 (DDR 1)
- data-description record 2 (DDR 2)
- observation reports

The DDRs have a fixed length and are positioned at the beginning of the file. After the DDRs the observation reports follow, one after another, until the end of the file. The observation reports are of variable length.

The extraction of data from the CMA file, and the storing of data in the CMA file, require a machine that supports 64 bits precision for real and at least 32 bits precision for integer. If these requirements are fulfilled the CMA file is machine independent.

6.2 CMA DDR FORMAT

The DDRs are both 3072 words long and hold information about the CMA file and its content. They consist of three



sections, each 1024 words long. The first section holds information of the type integer (I), the second of the type character (IC) and the third of the type real (R). Some of the information is packed as integers (IP). In subsections 6.2.1 and 6.2.2 the the formats of the DDRs are described in table form. The type of information and content of each word position is described.

The positions in the DDRs are mostly referred to through pointers. These pointers are given in brackets in the column describing the word positions. The pointers are relative to the shaded offset positions. This means, for example, that the position 1024+10 in DDR1 is referred to as 1024+NCD1EN2.

Information about the units can be found in brackets in the column describing the content of each word position. In some cases, when the content is a non-dimensional code figure, it is referred to as a code-description section (CDS). If the information is packed, a packing-description section (PDS) is referred to.

6.2.1 DDR1 Format

The length of the section following the integer section offset 2 is dependent on the parameters JPXTSL, and NTSL_STEPSIZE. JPXTSL is the maximal number of time-slots allowed. NTSL_STEPSIZE describes the number of words in integer section 2 occupied by each time-slot

TABLE 6.1 DATA DESCRIPTION RECORD 1

WORD	TYPE	CONTENT
0+	I	Integer section offset 1
1 (NCD1LN)	I	Length of first DDR (words)
2 (NCD1NIS)	I	Number of non integer sections (numeric)
3 (NCD1TF)	I	Type of first non integer section (code) CDS 6.5.1
4 (NCD1TS)	I	Type of second non integer section (code) CDS 6.5.1
5 (NCD1IL)	I	Length of integer section (words)
6 (NCD1LFS)	I	Length of first non integer section (words)
7 (NCD1LSS)	I	Length of second non integer section (words)
8 (NCD1NL)	I	Length of next DDR (words)
9 (NCD1CT)	IP	Creation time (numeric) PDS 6.4.1
10 (NCD1CD)	IP	Creation date (numeric) PDS 6.4.2
11 (NCD1OT)	IP	Time of the middle of observation period (numeric) PDS 6.4.1
12 (NCD1OD)	IP	Date of the middle of observation period (numeric) PDS 6.4.2
13 (NCD1NS)	I	Number of seconds per time unit (numeric)
14 (NCD1OP)	I	Length of observation period in time units (numeric)
15 (NCD1NPU)	I	Number of planned updates (numeric)
16 (NCD1NUP)	I	Number of performed updates (numeric)
17 (NCD1AD)	I	Number of additional departures (numeric)
18 (NCD1ND)	I	Number of DDRs (numeric)
19 (NCD1DR)	I	Number of data records (numeric)

TABLE 6.1 DATA DESCRIPTION RECORD 1

WORD	TYPE	CONTENT
20 (NCD1LD)	I	Maximum length of DDR (words)
21 (NCD1MR)	I	Maximum length of data record (words)
22 (NCD1RM)	I	Maximum length of observation report (words)
23 (NCD1NF)	I	Total number of ECMA files (numeric)
24 (NCD1SQ)	I	ECMA file sequence number (numeric)
25 (NCD1TM)	I	Number of time slots (numeric)
26 (NCD1MOT)	I	Maximum number of observation types (numeric)
27 (NCD1TO)	I	Total number of observations (numeric)
28 (NCD1NSY)	I	Number of SYNOP observations (numeric)
29 (NCD1NAI)	I	Number of AIREP observations (numeric)
30 (NCD1NSA)	I	Number of SATOB observations (numeric)
31 (NCD1NDB)	I	Number of DRIBU observations (numeric)
32 (NCD1NTE)	I	Number of TEMP observations (numeric)
33 (NCD1NPI)	I	Number of PILOT observations (numeric)
34 (NCD1NSM)	I	Number of SATEM non radiance observations (numeric)
35 (NCD1NT)	I	Number of SATEM radiance observations (numeric)
36 (NCD1NPA)	I	Number of PAOB observations (numeric)
37 (NCD1SC)	I	Number of Scatterometer observations (numeric)
38 (NCD1NRR)	I	Number of Raw Radiance observations (numeric)
39 (NCD1NSSM)	I	Number of SATEM SSM/I observations (numeric)
40-50	I	Reserved
51 (NCD1AL)	I	Total length of CMA (words)
52 (NCD1TVA)	I	Type of variational analysis (code) CDS 6.5.2
53 (NCD1CON)	I	IFS configuration number (code) CDS 6.5.3
54 (NCD1NST)	I	IFS number of time steps (numeric)
55 (NCD1NC)	I	Basic length of report header (words)
56 (NCD1BLB)	I	Basic length of report header body entry (words)
57 (NCD11DL)	I	Number of 1D-VAR retrieved levels (numeric)
58 (NCD11DV)	I	Number of 1D-VAR upper air retrieved variables (numeric)
59 (NCD11DS)	I	Number of 1D-VAR single level retrieved variables (numeric)
60 (NCD1MPF)	IP	Model profile indicator bit-map (numeric) PDS 6.4.3
61 (NCD1MSV)	I	Number of model surface variables (numeric)
62 (NCD1MLV)	I	Number of model levels (numeric)
63 (NCD1MUV)	I	Number of model upper air variables (numeric)



TABLE 6.1 DATA DESCRIPTION RECORD 1

WORD	TYPE	CONTENT
64 (NCD1NBS)	I	Number of input/output BUFR files 6 hour timeslot (numeric)
65 (NCD11BSD)	IP	First BUFR 6 hour time slot date (numeric) PDS 6.4.2
66 (NCD11BST)	IP	First BUFR 6 hour time slot time (numeric) PDS 6.4.1
67 (NCD12BSD)	IP	Second BUFR 6 hour time slot date (numeric) PDS 6.4.2
68 (NCD12BST)	IP	Second BUFR 6 hour time slot time (numeric) PDS 6.4.1
69 (NCD13BSD)	IP	Third BUFR 6 hour time slot date (numeric) PDS 6.4.2
70 (NCD13BST)	IP	Third BUFR 6 hour time slot time (numeric) PDS 6.4.1
71 (NCD14BSD)	IP	Fourth BUFR 6 hour time slot date (numeric) PDS 6.4.2
72 (NCD14BST)	IP	Fourth BUFR 6 hour time slot time (numeric) PDS 6.4.1
73 (NCD15BSD)	IP	Fifth BUFR 6 hour time slot date (numeric) PDS 6.4.2
74 (NCD15BST)	IP	Fifth BUFR 6 hour time slot time (numeric) PDS 6.4.1
75 (NCD11DLS)	I	Number of 1D-VAR (SSM/I) retrieved levels (numeric)
76 (NCD11DVS)	I	Number of 1D-VAR (SSM/I) upper air retrieved variables (numeric)
77 (NCD11DSS)	I	Number of 1D-VAR (SSM/I) single level retrieved variables (numeric)
78-100	I	Not defined
101 (NCD1TSL_NUMSLOTS)	I	Number of timeslot information present (numeric)
102 (NCD1TSL_WORDS)	I	Actual number of words per timeslot (numeric)
103 (NCD1TSL_INIT_DATE)	IP	Start date of the whole assimilation period (numeric) PDS 6.4.2
104 (NCD1TSL_INIT_TIME)	IP	Start time of the whole assimilation period (numeric) PDS 6.4.1
105 (NCD1TSL_BACKWARD_TIME)	I	Backward deltatime (min)
106 (NCD1TSL_FORWARD_TIME)	I	Forward delta time (min)
107 (NCD1TSL_TIME_DELTA)	I	Nominal delta time of a timeslot (min)
FOR i=1,JPXTSL	I	Integer section offset 2
108 (NCD1TSL_TIMESLOT_NO) +(i-1)*NTSL_STEPSTIZE	I	The time slot number in concern (numeric)
109 (NCD1TSL_END_DATE) +(i-1)*NTSL_STEPSTIZE	IP	End date (numeric) PDS 6.4.2
110 (NCD1TSL_END_TIME) +(i-1)*NTSL_STEPSTIZE	IP	End time (numeric) PDS 6.4.1
111 (NCD1TSL_DATALEN) +(i-1)*NTSL_STEPSTIZE	I	CMA length (words)
112 (NCD1TSL_NOBS) +(i-1)*NTSL_STEPSTIZE	I	Number of observations (numeric)
113 (NCD1TSL_WEIGHT) +(i-1)*NTSL_STEPSTIZE	I	Approximate observation weight for partition (non dimensional)

TABLE 6.1 DATA DESCRIPTION RECORD 1

WORD	TYPE	CONTENT
114 (NCD1TSL_NWLAT) +(i-1)*NTSL_STEPSTIZE	I	North-West millilatitide of the partition (degrees*1000)
115 (NCD1TSL_NWLON) +(i-1)*NTSL_STEPSTIZE)	I	North-West millilongitude of the partition (degrees*1000)
116 (NCD1TSL_SELAT) +(i-1)*NTSL_STEPSTIZE)	I	South-East millilatitide of the partition (degrees*1000)
117 (NCD1TSL_SELON) +(i-1)*NTSL_STEPSTIZE	I	South-East millilongitude of the partition (degrees*1000)
118 (NCD1TSL_OBSTYPE1) +(i-1)*NTSL_STEPSTIZE	I	Number of observations of type 1 (numeric) ¹
119 (NCD1TSL_OBSTYPE2) +(i-1)*NTSL_STEPSTIZE	I	Number of observations of type 2 (numeric) ¹
120 (NCD1TSL_OBSTYPE3) +(i-1)*NTSL_STEPSTIZE	I	Number of observations of type 3 (numeric) ¹
121 (NCD1TSL_OBSTYPE4) +(i-1)*NTSL_STEPSTIZE	I	Number of observations of type 4 (numeric) ¹
122 (NCD1TSL_OBSTYPE5) +(i-1)*NTSL_STEPSTIZE	I	Number of observations of type 5 (numeric) ¹
123 (NCD1TSL_OBSTYPE6) +(i-1)*NTSL_STEPSTIZE	I	Number of observations of type 6 (numeric) ¹
124 (NCD1TSL_OBSTYPE7) +(i-1)*NTSL_STEPSTIZE	I	Number of observations of type 7 (numeric) ¹
125 (NCD1TSL_OBSTYPE8) +(i-1)*NTSL_STEPSTIZE	I	Number of observations of type 8 (numeric) ¹
126 (NCD1TSL_OBSTYPE9) +(i-1)*NTSL_STEPSTIZE	I	Number of observations of type 9 (numeric) ¹
127 (NCD1TSL_OBSTYPE10) +(i-1)*NTSL_STEPSTIZE	I	Number of observations of type 10 (numeric) ¹
(128+(i-1)*NTSL_STEPSTIZE)- (107+i*NTSL_STEPSTIZE)	I	Not defined
JPXTSL*NTSL_STEPSTIZE+107+	I	Integer section offset 3
1-(1024-107-JPXTSL*NTSL_STEPSTIZE)	I	Not defined
1024+	I	Character section offset
1 (NCD1PV1)	IC	Pre-processor version, character 1 (character)
2 (NCD1PV2)	IC	Pre-processor version, character 2 (character)
3 (NCD1PV3)	IC	Pre-processor version, character 3 (character)
4 (NCD1PV4)	IC	Pre-processor version, character 4 (character)
5 (NCD1PV5)	IC	Pre-processor version, character 5 (character)
6 (NCD1PV6)	IC	Pre-processor version, character 6 (character)
7 (NCD1PV7)	IC	Pre-processor version, character 7 (character)
8 (NCD1PV8)	IC	Pre-processor version, character 8 (character)
9 (NCD1EN1)	IC	Experiment name, character 1 (character)



TABLE 6.1 DATA DESCRIPTION RECORD 1

WORD	TYPE	CONTENT
10 (NCD1EN2)	IC	Experiment name, character 2 (character)
11 (NCD1EN3)	IC	Experiment name, character 3 (character)
12 (NCD1EN4)	IC	Experiment name, character 4 (character)
13 (NCD1EN5)	IC	Experiment name, character 5 (character)
14 (NCD1EN6)	IC	Experiment name, character 6 (character)
15 (NCD1EN7)	IC	Experiment name, character 7 (character)
16 (NCD1EN8)	IC	Experiment name, character 8 (character)
17 (NCD1EN9)	IC	Experiment name, character 9 (character)
18 (NCD1EN10)	IC	Experiment name, character 10 (character)
19 (NCD1EN11)	IC	Experiment name, character 11 (character)
20 (NCD1EN12)	IC	Experiment name, character 12 (character)
21 (NCD1EN13)	IC	Experiment name, character 13 (character)
22 (NCD1EN14)	IC	Experiment name, character 14 (character)
23 (NCD1EN15)	IC	Experiment name, character 15 (character)
24 (NCD1EN16)	IC	Experiment name, character 16 (character)
25 (NCD1VAT)	IC	Variational job type. Not used
26-1024	IC	Not defined
2048+	R	Real section offset
1-1024	R	Not defined

¹ Observation type codes are described in CDS [6.5.5](#)

6.2.2 DDR2 Format

TABLE 6.2 DATA DESCRIPTION RECORD 2

WORD	TYPE	CONTENT
0+	I	Integer section offset
1 (NCD2LN)	I	Length of second DDR (words)
2 (NCD2NI)	I	Number of non integer sections (numeric)
3 (NCD2T1)	I	Type of first non integer section (code) CDS 6.5.1
4 (NCD2T2)	I	Type of second non integer section (code) CDS 6.5.1
5 (NCD2IL)	I	Length of integer section (words)
6 (NCD2LFS)	I	Length of first non integer section (words)
7 (NCD2LSS)	I	Length of second non integer section (words)
8 (NCD2LND)	I	Length of next DDR (words)
9 (NCD2TL)	I	Number of clear SATEM thickness layers (numeric)

TABLE 6.2 DATA DESCRIPTION RECORD 2

WORD	TYPE	CONTENT
10 (NCD2TY)	I	Number of cloudy SATEM thickness layers (numeric)
11 (NCD2TM)	I	Number of microwave SATEM thickness layers (numeric)
12 (NCD2SAI1)	I	Satellite X identity (code) CDS 6.5.4
13 (NCD2SAT1)	I	Number of satellite X reports present (numeric)
14 (NCD2SAI2)	I	Satellite Y identity (code) CDS 6.5.4
15 (NCD2SAT2)	I	Number of satellite Y reports present (numeric)
16 (NCD2SAI3)	I	Satellite Z identity (code) CDS 6.5.4
17 (NCD2SAT3)	I	Number of satellite Z reports present (numeric)
18 (NCD2SAI4)	I	Satellite P identity (code) CDS 6.5.4
19 (NCD2SAT4)	I	Number of satellite P reports present (numeric)
20 (NCD2SAI5)	I	Satellite R identity (code) CDS 6.5.4
21 (NCD2SAT5)	I	Number of satellite R reports present (numeric)
22 (NCD2SAI6)	I	Satellite Q identity (code) CDS 6.5.4
23 (NCD2SAT6)	I	Number of satellite Q reports present (numeric)
24-25	I	Reserved
26 (NCD2NS)	I	Number of simulations performed (numeric)
27 (NCD2SD)	I	Number of the following words (NS) used to store bit map indicating additional departures created (numeric)
28-(28+NS-1)	IP	Additional departure bit-map (numeric) PDS 6.4.4
(28+NS)-1024	I	Not defined
1024 +	I	Character section offset
1-1024	IC	Not defined
2048+	I	Real section offset
1-1024	R	Not defined

6.3 OBSERVATION-REPORT FORMAT

A single observation report is presented in a format called CMA observation-report format (CMAORF). The observation-report format consists of the following two parts:

- observation header
- observation body

Both the header and the body are of variable length. The header is a single entry, whereas the body comprises several entries. The body entry is essentially a single piece of observed information with its connected relevant information. Every observation-report header and body entry have a fixed part and a dependent part with variable length. The observation report contains information of the types integer (I) and real (R). In order to have information about the station identity, the fixed part of the header also contains some information of the type character (IC). Some of the data are packed as integers (IP) and some are coded.

Subsections 6.3.1 and 6.3.2 describe the observation-header and body-entry formats in table form. The positions



in the observation report are mostly referred to through pointers. These pointers are given in brackets in the column describing the word position. The pointers are relative to the shaded offset positions. This means, for example, that the word position describing the instrument specification is referred to as 42+NCMINS(OCTP,OBTP).

Packed information is described in packing description sections (PDS). Information about the units can be found in brackets in the column describing the content of each word position. The coded information is described in referenced BUFR-code tables (BCT) or code-description sections (CDS).

6.3.1 Observation Report Header Format

The fixed part of the observation report header is 42 words long. The content and length of the dependent part depends on observation/code type, and on whether the option to append a model profile (+surface variables) is used. For the observation/code types SATEM (radiance) and SATEM (SSM/I) it is also dependent on the number of levels and variables used in 1D-VAR.

6.3.1 (a) Observation Report Header Format Fixed Part.

TABLE 6.3 HEADER FIXED PART

WORD	TYPE	CONTENT
0+	I	Header fixed format offset
1 (NCMRLN)	I	Total report length (words)
2 (NCMIRLN)	I	Integers part report length (words)
3 (NCMHLN)	I	Total header length (words)
4 (NCMIHL)	I	Integers part header length (words)
5 (NCMHFLN)	I	Total fixed header length (words)
6 (NCMFHILN)	I	Integers section fixed part header length (words)
7 (NCMFHCLN)	I	Characters section fixed part header length (words)
8 (NCMOHILN)	I	Optional part integers section length (words)
9 (NCMBLN)	I	Total body entry length (words)
10 (NCMBILN)	I	Integers part body entry length (words)
11 (NCMBFL)	I	Total fixed part body entry length (words)
12 (NCMBFIL)	I	Integers part fixed body entry length (words)
13 (NCMBRL)	I	Total run dependent part body entry length (words)
14 (NCMBRIL)	I	Integers part run dependent body entry length (words)
15 (NCMBTL)	I	Total type dependent part length (words)
16 (NCMBTIL)	I	Integers type dependent part length (words)
17 (NCMONM)	I	Observation sequence number (numeric)
18 (NCMOTP)	I	Observation type (code) CDS 6.5.5
19 (NCMOCH)	IP	Observation characteristics (numeric) PDS 6.4.5
20 (NCMDAT)	IP	Observation date (numeric) PDS 6.4.2
21 (NCMETM)	IP	Observation exact time (numeric) PDS 6.4.1

TABLE 6.3 HEADER FIXED PART

WORD	TYPE	CONTENT
22 (NCMNLV)	I	Number of body entries (numeric)
23 (NCMRFL)	IP	Reports flags (numeric) PDS 6.4.6
24 (NCMRST)	IP	Reports status (numeric) PDS 6.4.7
25 (NCMREV1)	IP	Reports events, part 1 (numeric) PDS 6.4.8
26 (NCMRBLE)	IP	Reports blacklist events (numeric) PDS 6.4.9
27 (NCMBOX)	I	Sorting box (numeric)
28 (NCMSTD)	I	Site dependant
29 (NCMSID)	IC	Station identity, character 1 (character)
30 (NCMSID2)	IC	Station identity, character 2 (character)
31 (NCMSID3)	IC	Station identity, character 3 (character)
32 (NCMSID4)	IC	Station identity, character 4 (character)
33 (NCMSID5)	IC	Station identity, character 5 (character)
34 (NCMSID6)	IC	Station identity, character 6 (character)
35 (NCMSID7)	IC	Station identity, character 7 (character)
36 (NCMSID8)	IC	Station identity, character 8 (character)
37 (NCMLAT)	R	Latitude (radians)
38 (NCMLON)	R	Longitude (radians)
39 (NCMALT)	R	Station altitude (m)
40 (NCMMOR)	R	Models orography (m)
41 (NCMTLA)	R	Transformed latitude (radians)
42 (NCMTLO)	R	Transformed longitude (radians)

6.3.1 (b) *Observation-report header format observation/code-type dependent part*. There is an option to add a model profile (+ surface variables) at the end of the observation/code-type dependent part of the header. If this option is used, the header length of the observation/code type in question is increased with MDPRF words.

The value of MDPRF is given by the expression:

$$\text{MDPRF} = \text{NOMODSV} + \text{NOMODUV} * \text{NOMODLV},$$

where:

NOMODSV is the number of surface variables

NOMODUV is the number of upper air variables

NOMODLV is the number of vertical levels

For the SATEM (radiance) observation/code type, the number of words in the section following offset position 3 is dependent on the number of levels, NO1DVLV, and of variables, NO1DVVA, used in 1D-VAR. In the case of the SATEM (SSM/I) observation/code type, the number of words following offset position 3 depends on the value of the number of levels used in 1D-VAR for SATEM (SSM/I), NO1DVLVS.

Some of the parameters in the parts corresponding to observation-code types SATEM (radiance) and SATEM (SSM/I) are just passed on from BUFR to CMA, without changing their formats. For some of these parameters



there are two types of information specified in the column denoted TYPE. The first type is the one which really explains what kind of value the word position contains. The second one, which is in brackets, indicates what type the information in the word position is considered as, when data are put into word positions 2 and 4 in the fixed header part of the observation report.

Notice that the values corresponding to word positions 43 and 44 are given by the matrix elements NCMINS(OCTP,OBTP) and NCMREV2(OCTP,OBTP), respectively. OBTP denotes the matrix row corresponding to each observation type and OCTP denotes the position in the row that is occupied by each observation-code type (see CDS 6.5.5) for a description of the observation types and observation-code types). For the moment, all of the matrix elements in NCMINS hold the value 1 and all of the elements in NCMREV2 hold the value 2.

SYNOP/AIREP/DRIBU/TEMP/PILOT/SATEM (non radiance)/PAOB/RAW RADIANCE:

TABLE 6.4 HEADER OBS/CODE TYPE DEP. PART: SYNOP/AIREP/DRIBU/TEMP/PILOT/SATEM/PAOB/RAW RADIANCE

WORD	TYPE	CONTENT
42+	I	Header obs/code type dependent format offset
1 (NCMINS(OCTP,OBTP))	IP	Instrument specification (numeric) PDS 6.4.10
2 (NCMREV2(OCTP,OBTP))	IP	Reports events, part 2 (numeric) PDS 6.4.11
3-(MDPRF+2)	R	Model profile

SATOB:

TABLE 6.5 HEADER OBS/CODE TYPE DEP. PART: SATOB

WORD	TYPE	CONTENT
42+	I	Header obs/code type dependent format offset
1 (NCMINS(OCTP,OBTP))	IP	Instrument specification (numeric) PDS 6.4.10
2 (NCMREV2(OCTP,OBTP))	IP	Reports events, part 2 (numeric) PDS 6.4.11
3 (NCMSBCMM)	R	Cloud motion comparison method (code) BCT 2023
4 (NCMSBIUP)	R	Instrument data used in process (code) BCT 2021
5 (NCMSBDPT)	R	Data processing technique used (code) BCT 2022
6-(MDPRF+5)	R	Model profile

SATEM (radiance):

TABLE 6.6 HEADER OBS/CODE TYPE DEP. PART: SATEM (RADIANCE)

WORD	TYPE	CONTENT
42 +	I	Header obs/code type dependent format offset 1 (pos. 3-17 holds "passed on parameters")
1 (NCMINS(OCTP,OBTP))	IP	Instrument specification (numeric) PDS 6.4.10
2 (NCMREV2(OCTP,OBTP))	IP	Reports events, part 2 (numeric) PDS 6.4.11

TABLE 6.6 HEADER OBS/CODE TYPE DEP. PART: SATEM (RADIANCE)

WORD	TYPE	CONTENT
3 (NCMOE)	R	Solar elevation (degrees)
4 (NCMCHU)	R	Satellite channel(s) used in computation (code) BCT 2025
5 (NCMDPT)	R	Satellite data processing technique used (code) BCT 2022
6 (NCMSLC)	I (R)	Satellite location counter (numeric)
7 (NCMVS1)	R	Vertical significance 1 (code) BCT 8003
8 (NCMOZO)	R	Ozon (DU)
9 (NCMVS2)	R	Vertical significance 2 (code) BCT 8003
10 (NCMPP1)	R	Pressure 1 (Pa)
11 (NCMCLC)	R	Cloud cover (%)
12 (NCMVS3)	R	Vertical significance 3 (code) BCT 8003
13 (NCMLSQ)	R	Land/Sea qualifier (code) BCT 8012
14 (NCMHLS)	R	Height of land surface (m)
15 (NCMSKT)	R	Skin temperature (K)
16 (NCMPP2)	R	Pressure 2 (Pa)
17 (NCMVS4)	R	Vertical significance 4 (code) BCT 8003
18 (NCM1DIT)	I (R)	1D-VAR iteration number (numeric)
19 (NCM1DER)	R	1D-VAR error(s). Not used
20 (NCMIDCU)	R	1D-VAR satellite channel(s) used (code) BCT 2025
21 (NCMIDCU1)	R	1D-VAR satellite channel(s) used (code) BCT 2025
22 (NCM1DPF)	R	PRESAT summary flags. Not used
23 (NCM11DIN)	I (R)	1D-VAR number of iterations for convergence (numeric)
24 (NCM11DFI)	I (R)	1D-VAR failure indicator (code) CDS 6.5.15
42 + 24 +	I	Header obs/code type dependent format offset 2 (1D-VAR surface variable section)
1 (NCM1DBP)	R	Background surface pressure (Pa)
2 (NCM1DAP)	R	1D-VAR adjusted surface pressure (Pa)
3 (NCM1DBST)	R	Background skin temperature (K)
4 (NCM1DAST)	R	1D-VAR adjusted skin temperature (K)
5 (NCM1DB2T)	R	Background 2m temperature (K)
6 (NCM1DA2T)	R	1D-VAR adjusted 2m temperature (K)
7 (NCM1DB2Q)	R	Background 2m specific humidity (kg/kg)
8 (NCM1DA2Q)	R	1D-VAR adjusted 2m specific humidity (kg/kg)
9 (NCM1DBME)	R	Background microwave surface emissivity (non dimensional)
10 (NCM1DAME)	R	1D-VAR adjusted microwave surface emissivity (non dimensional)
11 (NCM1DBTO)	R	Background total column ozone (DU)
12 (NCM1DATO)	R	1D-VAR adjusted total column ozone (DU)
13 (NCM1DBCP)	R	Background cloud top pressure (Pa)



TABLE 6.6 HEADER OBS/CODE TYPE DEP. PART: SATEM (RADIANCE)

WORD	TYPE	CONTENT
14 (NCM1DACP)	R	1D-VAR adjusted cloud top pressure (Pa)
15 (NCM1DBCA)	R	Background cloud amount (code) BCT 20011
16 (NCM1DACA)	R	1D-VAR adjusted cloud amount (code) BCT 20011
FOR ILEV=1,NO1DVLV 42+24+16+(ILEV-1)*NO1DVVA+	I	Header obs/code type dependent format offset 3 (1D-VAR level variable section)
1 (NCM1DVP)	R	Pressure (Pa)
2 (NCM1DVT1)	R	Temperature 1 (K)
3 (NCM1DVT2)	R	Temperature 2 (K)
4 (NCM1DVQ1)	R	Specific humidity 1 (kg/kg)
5 (NCM1DVQ2)	R	Specific humidity 2 (kg/kg)
6-NO1DVVA	R	Not defined
NO1DVVA*NO1DVLV+ 42+24+16+	I	Header obs/code type dependent format offset 4
1-MDPRF	R	Model profile

SATEM (SSM/I):

TABLE 6.7 HEADER OBS/CODE TYPE DEP. PART: SATEM (SSM/i)

WORD	TYPE	CONTENT
42+	I	Header obs/code type dependent format offset 1 (pos. 3-34 holds "passed on parameters")
1 (NCMINS(OCTP,OBTP))	IP	Instrument specification (numeric) PDS 6.4.10
2 (NCMREV2(OCTP,OBTP))	IP	Reports events, part 2 (numeric) PDS 6.4.11
3 (NCMORNO)	I (R)	Orbit number (numeric)
4 (NCMSLNO)	I (R)	Scan line number (numeric)
5 (NCMPNAS)	I (R)	Position number along scan (numeric)
6 (NCMTOS)	R	Type of surface (code) BCT 13202
7 (NCMVSG)	R	Vertical significance (code) BCT 8003
8 (NCME1LA)	R	First extra point latitude (degrees)
9 (NCME1LO)	R	First extra point longitude (degrees)
10 (NCME1TQ)	R	First extra time qualifier (code) BCT 8193
11 (NCME1DA)	IP (R)	First extra date (numeric) PDS 6.4.2
12 (NCME1TI)	IP (R)	First extra time (numeric) PDS 6.4.1
13 (NCME1TS)	R	First extra type of surface (code) BCT 13202
14 (NCME1VS)	R	First extra vertical significance (code) BCT 8003
15 (NCME1BT1)	R	First extra point temperature 1 (K)
16 (NCME1BT2)	R	First extra point temperature 2 (K)



TABLE 6.7 HEADER OBS/CODE TYPE DEP. PART: SATEM (SSM/I)

WORD	TYPE	CONTENT
17 (NCME2LA)	R	Second extra point latitude (degrees)
18 (NCME2LO)	R	Second extra point longitude (degrees)
19 (NCME2TQ)	R	Second extra time qualifier (code) BCT 8193
20 (NCME2DA)	IP (R)	Second extra date (numeric) PDS 6.4.2
21 (NCME2TI)	IP (R)	Second extra time (numeric) PDS 6.4.1
22 (NCME2TS)	R	Second extra type of surface (code) BCT 13202
23 (NCME2VS)	R	Second extra vertical significance (code) BCT 8003
24 (NCME2BT1)	R	Second extra point temperature 1 (K)
25 (NCME2BT2)	R	Second extra point temperature 2 (K)
26 (NCME3LA)	R	Third extra point latitude (degrees)
27 (NCME3LO)	R	Third extra point longitude (degrees)
28 (NCME3TQ)	R	Third extra time qualifier BCT 8193
29 (NCME3DA)	IP (R)	Third extra date (numeric) PDS 6.4.2
30 (NCME3TI)	IP (R)	Third extra time (numeric) PDS 6.4.1
28 (NCME3TS)	R	Third extra type of surface (code) BCT 13202
29 (NCME3VS)	R	Third extra vertical significance (code) BCT 8003
33 (NCME3BT1)	R	Third extra point temperature 1 (K)
34 (NCME3BT2)	R	Third extra point temperature 2 (K)
35 (NCMSSMST)	R	SSM/I surface type (code) BCT 13202
36 (NCM1DSTQ)	I(R)	1D-VAR Surface type QC (code) CDS 6.5.14
37 (NCM1DNIT)	I (R)	1D-VAR number of iterations for convergence (numeric)
38 (NCM1DFIN)	I (R)	1D-VAR failure indicator (code) CDS 6.5.15
39 (NCMIES)	R	1D-VAR1D-VAR estimate of scattering (non dimensional)
40 (NCMSSISI)	R	SSM/I independent scattering index (non dimensional)
41 (NCM1DERR)	R	1D-VAR estimate of rain rate (mm/h)
42 (NCMSSERR)	R	SSM/I independent estimate of rain rate (mm/h)
43 (NCM1DREP)	R	1D-VAR retrieved error for TPW (kg/m ²)
44 (NCM1DREW)	R	1D-VAR retrieved error for wind speed (m/s)
45 (NCM1DREC)	R	1D-VAR retrieved error for cloud liquid water path (kg/m ²)
46 (NCMIEREP)	R	Independent estimate of error for TPW (kg/m ²)
47 (NCMIEREW)	R	Independent estimate of error for wind (m/s)
48 (NCMIEREC)	R	Independent estimate of error for cloud liquid water path (kg/m ²)
42+48+	I	Header obs/code type dependent format offset 2 (1D-VAR surface variable section)
1 (NCM1BPS)	R	Background surface pressure (Pa)
2 (NCM1BSTS)	R	Background skin temperature (K)
3 (NCM1B2TS)	R	Background 2m temperature (K)



TABLE 6.7 HEADER OBS/CODE TYPE DEP. PART: SATEM (SSM/I)

WORD	TYPE	CONTENT
4 (NCM1B2QS)	R	Background 2m specific humidity (kg/kg)
5 (NCM1A2QS)	R	1D-VAR adjusted 2 m specific humidity (kg/kg)
6 (NCM1BPWS)	R	Background PWC (kg/m ²)
7 (NCM1APWS)	R	1D-VAR adjusted PWC (kg/m ²)
8 (NCMSIPWS)	R	Independent estimate of PWC (kg/m ²)
9 (NCM1BCLS)	R	Background cloud liquid water (kg/m ²)
10 (NCM1ACLS)	R	1D-VAR adjusted cloud liquid water (kg/m ²)
11 (NCMSICLS)	R	Independent estimate of cloud liquid water (kg/m ²)
12 (NCM1BSUS)	R	Background 10 m u component (m/s)
13 (NCM1BSVS)	R	Background 10 m v component (m/s)
14 (NCM1ASWS)	R	1D-VAR adjusted 10 m wind speed (m/s)
15 (NCMSISWS)	R	Independent estimate of 10 m wind speed (m/s)
FOR ILEV=1,NO1DVLVS 42+48+15+(ILEV-1)*7+	I	Header obs/code type dependent format offset 3 (1D-VAR level variable section)
1 (NCM1DVPS)	R	Pressure (Pa)
2 (NCM1DVBT)	R	Background temperature (K)
3 (NCM1DVAT)	R	1D-VAR adjusted temperature (K)
4 (NCM1DVBQ)	R	Background specific humidity (kg/kg)
5 (NCM1DVAQ)	R	1D-VAR adjusted specific humidity (kg/kg)
6 (NCM1DVBC)	R	Background cloud liquid water (kg/m ²)
7 (NCM1DVAC)	R	1D-VAR adjusted cloud liquid water (kg/m ²)
42+48+15+7*NO1DVLVS+		Header obs/code type dependent format offset 4
1-(MDPRF)	R	Model profile

SCATTEROMETER:

TABLE 6.8 HEADER OBS/CODE TYPE DEP. PART: SCATTEROMETER

WORD	TYPE	CONTENT
42+	I	Header obs/code type dependent format offset
1 (NCMINS(OCTP,OBTP))	IP	Instrument specification (numeric) PDS 6.4.10
2 (NCMREV2(OCTP,OBTP))	IP	Reports events, part 2 (numeric) PDS 6.4.11
3 (NCMSCCNO)	I	Cell number (numeric)
4 (NCMSCPFL)	IP	Product flags PDS 6.4.12
5 (NCMSCSAT)	R	Satellite track (degrees)
6-(MDPRF+5)	R	Model profile

6.3.2 Observation-report-body entry format

The fixed part of the observation body entry is 20 words long. The content and length of the dependent part depends on observation/code type and the type of run.

6.3.2 (a) *Observation-report-body entry fixed format* .

TABLE 6.9 BODY ENTRY FIXED PART

WORD	TYPE	CONTENT
0 +	I	Body entry fixed format offset
1 (NCMVNM)	I	Variable number (code) CDS 6.5.6
2 (NCMVCO)	I	Vertical coordinate type (code) CDS 6.5.7
3 (NCMRDFL)	IP	Observation flags, RDB (numeric) PDS 6.4.13
4 (NCMFLG)	IP	Analysis datum flags (numeric) PDS 6.4.14
5 (NCMDSTA)	IP	Observation datum status (numeric) PDS 6.4.15
6 (NCMDEV1)	IP	Data events, part 1 (numeric) PDS 6.4.16
7 (NCMDBLE)	IP	Data blacklist events (numeric) PDS 6.4.17
8 (NCMESQN)	I	Body entry sequence number (numeric)
9 (NCMPPP)	R	Vertical coordinate reference 1
10 (NCMPRL)	R	Vertical coordinate reference 2
11 (NCMVAR)	R	Observed variable
12 (NCMOMN)	R	Observed minus analysed value
13 (NCMOMF)	R	Observed minus first guess value
14 (NCMFOE)	R	Final observation error
15 (NCMOER)	R	Observation error
16 (NCMRER)	R	Representativeness error
17 (NCMPER)	R	Persistence error
18 (NCMFGE)	R	First guess error
19 (NCMFGC1)	R	First guess check constant 1
20 (NCMFGC2)	R	First guess check constant 2

6.3.2 (b) *Observation-report body entry run-dependent part*. For both incremental and non-incremental runs, the number of words occupied by the run-dependent part of the observation header depends on the number of additional departures, TOTAD. For incremental runs the number of words occupied by the run-dependent part is also dependent on the number of updates, TOTUPD.

Incremental run:



TABLE 6.10 BODY ENTRY RUN DEP. PART: INCREMENTAL RUN

WORD	TYPE	CONTENT
FOR UP=1,TOTUPD 20 + (UP-1)*(4+TOTAD) +	I	Body entry run dependent format offset 1
(1+(UP-1)*(4+TOTAD)) (NCMIOM0(UP))	R	Observed-Update UP initial value
(2+(UP-1)*(4+TOTAD)) (NCMIFC1(UP))	R	Observed-Update UP higher resolution value
(3+(UP-1)*(4+TOTAD)) (NCMIFC2(UP))	R	Observed-Update UP lower resolution value
(4+(UP-1)*(4+TOTAD)) (NCMIOMN(UP))	R	Observed-Update UP final value
FOR UP=1,TOTUPD FOR AD=1,TOTAD 20+ (UP-1)*(4+TOTAD) + 4 +	I	Body entry run dependent format offset 2
AD (NCMIOMSN(AD,UP))	R	Observed-Update additional departures

Incremental Canari run (French O.I.):

TABLE 6.11 BODY ENTRY RUN DEP. PART: INCREMENTAL CANARI RUN

WORD	TYPE	CONTENT
FOR UP=1,TOTUPD 20+(UP-1)*(4+TOTAD)+	I	Body entry run dependent format offset 1
(1+(UP-1)*(4+TOTAD)) (NCMIOM0(UP))	R	Observed-Update UP initial value
(2+(UP-1)*(4+TOTAD)) (NCMIFC1(UP))	R	Observed-Update UP higher resolution value
(3+(UP-1)*(4+TOTAD)) (NCMIFC2(UP))	R	Observed-Update UP lower resolution value
(4+(UP-1)*(4+TOTAD)) (NCMIOMN(UP))	R	Observed-Update UP final value
FOR UP=1,TOTUPD FOR AD=1,TOTAD 20+(UP-1)*(4+TOTAD)+4+	I	Body entry run dependent format offset 2
AD (NCMIOMSN(AD,UP))	R	Observed-Update additional departures
20+TOTUPD*(4+TOTAD)+	I	Body entry run dependent format offset 3
1 (NCOMRBVC)	I	Vertical coordinate type (code) CDS 6.5.7
2 (NCOMRPBIO)	R	Pressure used in CANARI (log p)
3 (NCOMRBOE)	R	Observation standard deviation at bottom layer

Non-incremental run:

TABLE 6.12 BODY ENTRY RUN DEP. PART: NON INCREMENTAL RUN

WORD	TYPE	CONTENT
FOR AD=1,TOTAD 20+	I	Body entry run dependent format offset
AD (NCMIOMSN(AD,1))	R	Observed-Update additional departures

Non-incremental Canari run (French O.I.):

TABLE 6.13 BODY ENTRY RUN DEP. PART: NON INCREMENTAL CANARI RUN

WORD	TYPE	CONTENT
FOR AD=1,TOTAD 20+	I	Body entry run dependent format offset 1
AD (NCMIOMSN(AD,1))	R	Observed-Update additional departures
20+TOTAD+	I	Body entry run dependent format offset 1
1 (NCMRBVC)	I	Vertical coordinate type (code) CDS 6.5.7
2 (NCMRPBIO)	R	Pressure used in CANARI (log p)
3 (NCMRBOE)	R	Observation standard deviation at bottom layer

6.3.2 (c) *Observation-report body entry: observation/code-type dependent part* . The offset position (IOFF) off the observation/code type dependent part depends on the type of run, number of additional departures (TOTAD) and updates (TOTUPD) (see sub-subsection 6.3.2 (b)):

- Incremental run: $IOFF=20+TOTUPD*(4+TOTAD)$
- Incremental Canari run: $IOFF=20+TOTUPD*(4+TOTAD)+3$
- Non incremental run: $IOFF=20+TOTAD$
- Non incremental Canari run: $IOFF=20+TOTAD+3$

Notice that the values corresponding to word positions IOFF+1 are given by the matrix elements NCMDEV2(OCTP,OBTP). OBTP denotes the matrix-row corresponding to each observation type and OCTP denotes the position in the row that is occupied by each observation code type (see CDS 6.5.5 for a description of the observation types and observation code types). For the moment, all of the matrix elements in NCMDEV2 hold the value 1.

AIREP/SATOB/SATEM (non radiance)/DRIBU/PAOB/RAW RADIANCE:

TABLE 6.14 BODY ENTRY TYPE DEP. PART: AIREP/SATOB/SATEM/DRIBU/PAOB/RAW RADIANCE

WORD	TYPE	CONTENT
IOFF+	I	Body entry obs/code type dependent format offset
1 (NCMDEV2(OCTP,OBTP))	IP	Data events, part 2 (numeric) PDS 6.4.18

SYNOPSIS:



TABLE 6.15 BODY ENTRY TYPE DEP. PART: SYNOP

WORD	TYPE	CONTENT
IOFF+	I	Body entry obs/code type dependent format offset
1 (NCMDEV2(OCTP,OBTP))	IP	Data events, part 2 (numeric) PDS 6.4.18
2 (NCMSYPC)	IP	Pressure code bit-map (numeric) PDS 6.4.20

TEMP:

TABLE 6.16 BODY ENTRY TYPE DEP. PART: TEMP

WORD	TYPE	CONTENT
IOFF+	I	Body entry obs/code type dependent format offset
1 (NCMDEV2(OCTP,OBTP))	IP	Data events, part 2 (numeric) PDS 6.4.18
2 (NCMTELID)	IP	Level identifier bit-map (numeric) PDS 6.4.19
3 (NCMTETII)	R	Time increment (s)
4 (NCMTELTII)	R	Latitude increment (radians)
5 (NCMTELNI)	R	Longitude increment (radians)

PILOT:

TABLE 6.17 BODY ENTRY TYPE DEP. PART: PILOT

WORD	TYPE	CONTENT
IOFF+	I	Body entry obs/code type dependent format offset
1 (NCMDEV2(OCTP,OBTP))	IP	Data events, part 2 (numeric) PDS 6.4.18
2 (NCMPILID)	IP	Level identifier bit-map (numeric) PDS 6.4.19
3 (NCMPITII)	R	Time increment (s)
4 (NCMPILTI)	R	Latitude increment (radians)
5 (NCMPILNI)	R	Longitude increment (radians)

SATEM (radiance):

TABLE 6.18 BODY ENTRY TYPE DEP. PART: SATEM (RADIANCE)

WORD	TYPE	CONTENT
IOFF+	I	Body entry obs/code type dependent format offset
1 (NCMDEV2(OCTP,OBTP))	IP	Data events, part 2 (numeric) PDS 6.4.18
2 (NCMTORB)	R	Radiance bias correction (K)
3 (NCM1DVC)	R	1D-VAR radiance cost (non dimensional)

TABLE 6.18 BODY ENTRY TYPE DEP. PART: SATEM (RADIANCE)

WORD	TYPE	CONTENT
4 (NCMTORDE)	R	Radiance departure (K)

SATEM (SSM/I):

TABLE 6.19 BODY ENTRY TYPE DEP. PART: SATEM (SSM/I)

WORD	TYPE	CONTENT
IOFF+	I	Body entry obs/code type dependent format offset
1 (NCMDEV2(OCTP,OBTP))	IP	Data events, part 2 (numeric) PDS 6.4.18
2 (NCMSSRB)	R	Radiance bias correction (K)
3 (NCMS1DVC)	R	1D-VAR radiance cost (non dimensional)
4 (NCMSSRDE)	R	Radiance departure (K)

SCATTEROMETER:

TABLE 6.20 BODY ENTRY TYPE DEP. PART: SCATTEROMETER

WORD	TYPE	CONTENT
IOFF+	I	Body entry obs/code type dependent format offset
2 (NCMDEV2(OCTP,OBTP))	IP	Data events, part 2 (numeric) PDS 6.4.18
3 (NCMSCBAA)	R	Beam azimuth angle (degrees)
4 (NCMSCBIA)	R	Beam incidence angle (degrees)
5 (NCMSCKP)	R	K _p Instrument noise (non dimensional)
6 (NCMSCIRF)	R	Inversion resolution of first solution (non dimensional)
7 (NCMSCIRS)	R	Inversion residual of second solution (non dimensional)
8 (NCMSCDIS)	R	Directional skill (non dimensional)

6.4 PACKING DESCRIPTION SECTIONS (PDS)

In order to reduce the size of the CMA file, and the memory occupied by the CMA, there are some variables in the DDRs and observation reports that are packed. The packing structures are described in detail in Packing Description Sections (PDS) 6.4.1 –6.4.20 . In those cases when the information is coded, it is described in the referenced WMO code tables, BUFR Code Tables (BCT) or Code Description Sections (CDS).

6.4.1 PDS time

The time information is packed in the format:

HHMMSS

where:



HH-Hour
MM-Minute
SS-Second

6.4.2 PDS date

The date information is packed in the format:

YYYYMMDD

where:

YYYY-Year
MM-Month
DD-Day

6.4.3 PDS-model-profile indicator bit map

Bit position 0 set to 1 indicates a possibility to add a model profile (+surface variables) to a requested observation type. This is done if the bit position corresponding to the observation type is set to 1.

TABLE 6.21 MODEL PROFILE INDICATOR BIT-MAP

Bit	Description
0	Model profile
1	SYNOP model profile
2	AIREP model profile
3	SATOB model profile
4	DRIBU model profile
5	TEMP model profile
6	PILOT model profile
7	SATEM model profile
8	PAOB model profile
9	Scatterometer model profile
10	Raw Radiance model profile
11-31	Not defined

6.4.4 PDS bit map, indicating additional departures saved

Sequence of bits. If bit number n is set to 1 the departure from the n th simulation is saved.

6.4.5 PDS-observation characteristics

TABLE 6.22 OBSERVATION CHARACTERISTICS

Bit	Description
0-9	Observation code type (code) CDS 6.5.5
10-19	Instrument type (code) CDS 6.5.8
20-25	Retrieval type (code) CDS 6.5.9
26-31	Geographical area (code) CDS 6.5.10

6.4.6 PDS-report flags

The bit map holds flag values for a number of parameters. Each parameter has its start positions in the bit-map defined by its specific offset bit position. All of the parameters have six associated bits and the offset positions (IOFF) corresponding to the different parameters are:

- latitude: 0
- longitude: 6
- date:12
- time:18
- altitude:24

TABLE 6.23 REPORTS FLAGS

Bit	Description
IOFF +	Parameter offset
0	1 - Human monitoring substitution 0 - No human monitoring substitution
1	1 - Q/C substitution 0 - No Q/C substitution
2	1 - Override flag is set 0 - Override flag is not set
3-4	0 - Parameter is correct 1 - Parameter is probably correct 2 - Parameter is probably incorrect 3 - Parameter is incorrect
5	1 - Parameter flag set by human monitor 0 - Parameter flag set by Q/C program or not checked

Bits 30-31 are not used.

6.4.7 PDS Reports Status

- Bit 0 - if set to 1 report is active
- Bit 1 - if set to 1 report is passive
- Bit 2 - if set to 1 report is rejected
- Bit 3 - if set to 1 report is blacklisted



Bit positions 4-31 are not used

6.4.8 PDS-report events, Part 1

Bit values set to 1 activate the flags

TABLE 6.24 REPORTS EVENTS, PART 1

Bit	Description
0	No data in the report
1	All data rejected
2	Bad reporting practice
3	Rejected due to RDB flag
4	Activated due to RDB flag
5	Activated by whitelist
6	Horizontal position out of range
7	Vertical position out of range
8	Time out of range
9	Redundant report
10	Report over land
11	Report over sea
12	Missing station altitude
13	Model surface too far from stat. alt
14	Report rejected through the namelist
15	Failed quality control
16-31	Not defined

6.4.9 PDS-report blacklist events

Bit values set to 1 activate the flags.

TABLE 6.25 REPORTS BLACKLIST EVENTS

Bit	Description
0	Monthly monitoring
1	Constant blacklisting
2	Experimental blacklisting
3	Whitelisting
4	Experimental whitelisting
5	Observation type blacklisted
6	Station ID. blacklisted



TABLE 6.25 REPORTS BLACKLIST EVENTS

Bit	Description
7	Code type blacklisted
8	Instrument type blacklisted
9	Date blacklisted
10	Time blacklisted
11	Latitude blacklisted
12	Longitude blacklisted
13	Station altitude blacklisted
14	Blacklisted due to land/sea mask
15	Blacklisted due to model orography
16	Blacklisted due to distance from reference point
17-31	Not defined



6.4.10 PDS instrument specification

SYNOP/TEMP/PAOB/SCATTEROMETER/RAW RADIANCE:

TABLE 6.26 INSTRUMENT SPECIFICATION: SYNOP/TEMP/PAOB/SCATTEROMETER/RAW RADIANCE

Bit	Description
0-9	Instrument type (code) CDS 6.5.8
7-31	Reserved

AIREP:

TABLE 6.27 INSTRUMENT SPECIFICATION: AIREP

Bit	Description
0-9	Instrument type (code) CDS 6.5.8
10-19	Phase of the flight (code) BCT 8004
20-31	Reserved

DRIBU

TABLE 6.28 INSTRUMENT SPECIFICATION: DRIBU

Bit	Description
0-9	Instrument type (code) CDS 6.5.8
10-13	K1 (code) No codes defined
14-17	K2 (code) No codes defined
18-21	K3 (code) No codes defined
22-31	Reserved

SATOB:

TABLE 6.29 INSTRUMENT SPECIFICATION: SATOB

Bit	Description
0-9	Instrument type (code) CDS 6.5.8
10-13	I1 (code) CDS 6.5.11
14-21	I2I2 (code) CDS 6.5.12
22-31	Reserved

PILOT:

TABLE 6.30 INSTRUMENT SPECIFICATION: PILOT

Bit	Description
0-9	Instrument type (code) CDS 6.5.8
10-13	A4 (code) No codes defined
14-31	Reserved

SATEM (non TOVS, non SSM/I):

TABLE 6.31 INSTRUMENT SPECIFICATION: SATEM (NON TOVS NON SSM/I)

Bit	Description
0-23	77 777 777B
24-27	I3, Instrument data used in processing. See WMO Manual On Codes, vol II, section II-4-E-8
31-28	I4, data processing technique. See WMO Manual On Codes, vol II, section II-4-E-9
38-32	I2I2, satellite name. See WMO Manual On Codes, vol II, section II-4-E-7
42-39	I1, country operating satellite. See WMO code 1761
49-43	IS, instrument specification code. See Research Manual 5, Table 7.5
49-63	Reserved

SATEM (SSM/I):

Instrument specification word not defined.

SATEM (TOVS):

TABLE 6.32 INSTRUMENT SPECIFICATION: SATEM (TOVS)

Bit	Description
0-9	Instrument type
10-11	A (code) CDS 6.5.13
12-13	B (code) CDS 6.5.13
14-15	C (code) CDS 6.5.13
16-18	V (code) CDS 6.5.13
19-21	W (code) CDS 6.5.13
22-24	X (code) CDS 6.5.13
25-27	Y (code) CDS 6.5.13
29-30	Z (code) CDS 6.5.13



TABLE 6.32 INSTRUMENT SPECIFICATION: SATEM (TOVS)

Bit	Description
30-31	Reserved

6.4.11 PDS-report events, part 2

Bit values set to 1 activate the flags.

SYNOP/AIREP/SATOB/DRIBU/TEMP/PILOT/SATEM/PAOB/RAW RADIANCE:

Bit 0-31 Not defined

SCATTEROMETER:

Bit 0 Thinned report

Bit 1-31 Not defined

6.4.12 PDS scatterometer-product flags

The ambiguous scatterometer wind will be used only if all bits in sequence 0-9 are set to 0. Bit values set to 1 activate the error message flags:

TABLE 6.33 SCATTEROMETER PRODUCT FLAGS

Bit	Description
All 0-9	Missing value
1	Sigma0 number 1 unusable
2	Sigma0 number 2 unusable
3	Sigma0 number 3 unusable
4	Rejected due to a too large distance to the cone
10-31	Not defined

6.4.13 PDS observation flags, RDB

The RDB flags consists of two different parts. The pressure flags part has the offset bit position (IOFF) 0 and the variable flags part has the offset bit position (IOFF) 15. Bit position 31 is not used. The usage of bit positions 0-30 is described in the table below.

TABLE 6.34 OBSERVATION FLAGS, RDB

Bit	Description
IOFF+	Parameter offset
0	1 - Human monitor substitution 0 - No human monitor substitution
1	1 - Q/C substitution 0 - No Q/C substitution



TABLE 6.34 OBSERVATION FLAGS, RDB

Bit	Description
2	1 - Override flag set 0 - Do not override flag set
3-4	0 - Parameter correct 1 - Parameter probably correct 2 - Parameter probably incorrect 3 - Parameter incorrect
5	1 - Param. flag set by human monitor 0 - Param. flag set by Q/C or not checked
6-7	0 - Param. judged correct by prev. analys. 1 - Param. was probably correct 2 - Param. was probably incorrect 3 - Param. incorrect
8	1 - Param. was used by prev. analys. 0 - Param. was not used
9-14	Not used

6.4.14 PDS analysis-datum flags

TABLE 6.35 ANALYSIS DATUM FLAGS

Bit	Description
0-3	Final flag 0 - Datum correct 1 - Datum probably correct 2 - Datum probably incorrect 3 - Datum incorrect 4-15 Not used
4-7	First guess flag 0 - Datum correct 1 - Datum probably correct 2 - Datum probably incorrect 3 - Datum incorrect 4-15 Not used
8-11	Departure flag 0 - Datum correct 1 - Datum probably correct 2 - Datum probably incorrect 3 - Datum incorrect 4-15 Not used
12-15	Variational quality control flag 0 - Datum correct 1 - Datum probably correct 2 - Datum probably incorrect 3 - Datum incorrect 4-15 Not used



TABLE 6.35 ANALYSIS DATUM FLAGS

Bit	Description
16-19	Blacklist flag 0 - Datum correct 1 - Datum probably correct 2 - Datum probably incorrect 3 - Datum incorrect 4-15 Not used
20-31	Not used

6.4.15 PDS observation-datum status

The combination of bit position and the value set to 1 makes the following statements true.

TABLE 6.36 OBSERVATION DATUM STATUS

Bit	Description
0	Datum is active
1	Datum is passive
2	Datum is rejected
3	Datum is blacklisted
4-31	Not defined

6.4.16 PDS data events, Part 1

Bit values set to 1 activate the flags.

TABLE 6.37 DATA EVENTS, PART 1

Bit	Description
0	Missing vertical coordinate
1	Missing observed value
2	Missing first guess value
3	Rejected due to RDB flag
4	Activated due to RDB flag
5	Activated by whitelist
6	Bad reporting practice
7	Vertical position out of range
8	Reference level position out of range
9	Too big first guess departure
10	Too big departure in assimilation
11	Too big observation error
12	Redundand datum

TABLE 6.37 DATA EVENTS, PART 1

Bit	Description
13	Redundant level
14	Report over land
15	Report over sea
16	Not an analysis variable
17	Duplicated datum/level
18	Too many surface data/levels
19	Multi level check
20	Level selection
21	Vertical consistency check
22	Vertical coordinate changed from Z to P
23	Datum rejected through the namelist
24	Combined flagging
25	Datum rejected due to rejected report
26	Variational QC performed
27-31	Not defined

6.4.17 PDS data-blacklist events

TABLE 6.38 DATA BLACKLIST EVENTS

Bit	Description
0	Pressure blacklisted
1	Variable name blacklisted
2	Blacklisted due to pressure code
3	Blacklisted due to distance from reference point
4	Blacklisted due to type of vertical coordinate
5	Blacklisted due to observed value
6	Blacklisted due to first guess departure
7-31	Not defined

6.4.18 PDS data events, Part 2

Bit values set to 1 activate the flags.

SYNOP/AIREP/SATOB/DRIBU/TEMP/PILOT/PAOB/SCATTEROMETER/RAW RADIANCE:

Bit 0-31 not defined

SATEM:



TABLE 6.39 DATA EVENTS, PART 2: SATEM

Bit	Description
0	Not predefined layer
1	Layer formed by thinning up
2	Layer formed by summing up
3	Channel not used in analysis
4	Overwritten by advar
5-31	Not defined

6.4.19 Level-identifier bit map

Bit values set to 1 activate the flags

TABLE 6.40 LEVEL-IDENTIFIER BIT MAP

Bit	Description
0	Max wind level
1	Tropopause
2	D part
3	C part
4	B part
5	A part
6	Surface level
7	Significant wind level
8	Significant temperature level
9-31	Not defined

6.4.20 SYNOP pressure-code bit map

Bit values set to 1 activate the flags.

TABLE 6.41 SYNOP PRESSURE CODE BIT-MAP

Code figure	Description
0 (NPRES CD(1))	Sea level pressure
1 (NPRES CD(2))	Station level pressure
2 (NPRES CD(3))	850 mb geopotential
3 (NPRES CD(4))	700 mb geopotential
4 (NPRES CD(5))	500 gpm pressure

TABLE 6.41 SYNOP PRESSURE CODE BIT-MAP

Code figure	Description
5 (NPRES(6))	1000 gpm pressure
6 (NPRES(7))	2000 gpm pressure
7 (NPRES(8))	3000 gpm pressure
8 (NPRES(9))	4000 gpm pressure
9 (NPRES(10))	900 mb geopotential
10 (NPRES(11))	1000 mb geopotential
11 (NPRES(12))	500 mb geopotential
12 (NPRES(13))	925 mb geopotential
13-31	Not defined

6.5 CODE-DESCRIPTION SECTIONS (CDS)

In subsections 6.5.1 – 6.5.15 codes connected to different variables are described. The codes are mainly referred to through pointers. In those cases when pointers exist they are positioned in brackets next to the code figure.

6.5.1 CDS type of section

TABLE 6.42 TYPE OF SECTION

Code figure	Description
1 (NINTESC)	Integer section
2 (NREALSC)	Real section
3 (NCHARSC)	Character section

6.5.2 CDS Type of Variational Analysis

TABLE 6.43 TYPE OF VARIATIONAL ANALYSIS

Code figure	Description
1	Canari run (French O.I.)
3	3D-VAR
4	4D-VAR



6.5.3 CDS IFS configuration number

TABLE 6.44 IFS CONFIGURATION NUMBER

Code figure	Description
101	4D-VAR with 3D prim. eq. model
111	4D-VAR prim. eq. tangent linear model
121	4D-VAR with shallow water model
122	4D-VAR with vorticity equation model
123	4D-VAR with linear gravity wave model
131	Incremental 4D-VAR
151	3D-VAR
701	Optimal interpolation with Canari

6.5.4 CDS satellite-identity codes

TABLE 6.45 SATELLITE IDENTITY CODES

Code figure	Description
208 (NNOAA10T)	NOAA10 TOVS
235 (NNOAA10S)	NOAA10 SATEM
201 (NNOAA11T)	NOAA11 TOVS
236 (NNOAA11S)	NOAA11 SATEM
202 (NNOAA12T)	NOAA12 TOVS
237 (NNOAA12S)	NOAA12 SATEM
206 (NNOAA14T)	NOAA14 TOVS
239 (NNOAA14S)	NOAA14 SATEM
202 (NNDMSP8)	DMPS8
203 (NNDMSP9)	DMPS9
204 (NNDMSP10)	DMPS10
205 (NNDMSP11)	DMPS11
245 (NNDMSP12)	DMPS12
246 (NNDMSP14)	DMPS14

6.5.5 CDS observation-type and observation-code-type codes

TABLE 6.46 OBSERVATION-TYPE AND OBSERVATION-CODE-TYPE CODES

Observation type	Observation code	Observation code-type description	Observation code-type code
SYNOP	1 (NSYNOP)	Land observation	11 (NSRSCD)
		Land automatic observation	14 (NATSCD)
		Ship observation	21 (NSHSCD)
		Ship abbreviates observation	22 (NABSCD)
		Shred observation	23 (NSHRED)
		Automatic ship observation	24 (NATSHS)
AIREP	2 (NAIREP)	Aircraft observation	141 (NAIRCD)
		CODAR observation	41 (NCODAR)
		COLBA observation	241 (NCOLBA)
		AMDAR observation	144 (NAMDAR)
		ACAR observation	145 (NACARS)
		Simulated observation	142 (NSIMAI)
SATOB	3 (NSATOB)	SATOB observation	88 (NSTBCD)
		SST observation	188 (NSST)
DRIBU	4 (NDRIBU)	DRIBU observation	165 (NDRBCD)
		BATHY observation	63 (NBATHY)
		TESAC observation	64 (NTESAC)
		ERS1 as DRIBU observation	160 (NDERS1)
TEMP	5 (NTEMP)	Land observation	35 (NLDTCO)
		Ship observation	36 (NSHTCO)
		Drop sonde observation	135 (NTDROP)
		ROCOB observation	39 (NROCOB)
		ROCOB ship observation	40 (NROCSH)
		Mobile observation	37 (NMBTMP)
		Simulated TEMP observation	137 (NSIMTE)
PILOT	6 (NPILOT)	Land observation	32 (NLDPCO)
		Ship observation	33 (NSHPCO)
		Wind-profiler	34 (NWPPCO)
SATEM	7 (NSATEM)	SATEM observation	86 (NSTMCO)
		High resolution satellite observation	186 (NSTOVS)
		High res. sim. DWL satellite obs.	185 (NSTDWL)
		High res. sim. TOVS satellite obs.	184 (NSTTOV)
		GTS BUFR SATEM observation	200 (NGTSTB)
		GTS BUFR SATEM clear radiance observation	201 (NGTST1)
		GTS BUFR SATEM clear radiance observation	202 (NGTST2)
		GTS BUFR SATEM retr. prof. and clear rad. rep.	210 (NGTHRB)
		GTS BUFR SATEM retr. prof. and clear rad. rep.	211 (NGTHR1)
		High res. 80 km BUFR non GTS SATEM retr. prof.	212 (NGTHR2)
		High res. 80 km BUFR non GTS SATEM clear rad. rep.	215 (NSSMI)
High res. 80 km BUFR non GTS SATEM prof. and clear rad. rep.			
SSM/I observation			
PAOB	8 (NPAOB)	PAOB observation	180 (NPABCO)



TABLE 6.46 OBSERVATION-TYPE AND OBSERVATION-CODE-TYPE CODES

Observation type	Observation code	Observation code-type description	Observation code-type code
Scatterometer	9 (NSCATT)	Scatterometer 1 observation	8 (NSCAT1)
		Scatterometer 2 observation	122 (NSCAT2)
		Scatterometer 3 observation	210 (NSCAT3)
Raw Radiance	10 (NRARAD)	Raw Radiances 1 observation	1 (NRARA1)

6.5.6 CDS variable-number codes

Directly after the variable description the units of the variables are described in brackets. In the case of coded information in this table it is referred to WMO code table numbers. The corresponding code table can be found in WMO Manual on Codes, vol 1.2.

TABLE 6.47 VARIABLE-NUMBER CODES

Code figure	Description
1 (NVNUMB(3))	Geopotential (m^2/s^2)
2 (NVNUMB(8))	Upper air temperature (K)
3 (NVNUMB(1))	Upper air u-component (m/s)
4 (NVNUMB(2))	Upper air v-component (m/s)
5 (NVNUMB(54))	Wind shear, du/dz (1/s)
6 (NVNUMB(55))	Wind shear, dv/dz (1/s)
7 (NVNUMB(63))	Specific humidity (kg/kg)
8 (NVNUMB(66))	Vertical speed (m/s)
9 (NVNUMB(6))	PWC (precipitable water content) (kg/m^2)
11 (NVNUMB(12))	Surface temperature (K)
19 (NVNUMB(58))	Layer relative humidity (%)
29 (NVNUMB(5))	Upper air relative humidity (%)
30 (NVNUMB(13))	Pressure tendency (Pa/3h)
39 (NVNUMB(10))	2m temperature (K)
40 (NVNUMB(11))	2m dew point (K)
41 (NVNUMB(56))	10m u-component (m/s)
42 (NVNUMB(57))	10m v-component (m/s)
56 (NVNUMB(67))	Virtual temperature (K)
57 (NVNUMB(3))	Thickness (m^2/s^2)
58 (NVNUMB(7))	2m relative humidity (%)
59 (NVNUMB(9))	Upper air dew point (K)
60 (NVNUMB(14))	Past weather, W (code) WMO 4561
61 (NVNUMB(15))	Present weather, ww (code) WMO 4677
62 (NVNUMB(16))	Visibility, V (code) WMO 4300

TABLE 6.47 VARIABLE-NUMBER CODES

Code figure	Description
63 (NVNUMB(17))	Type of high clouds, C_H (code) WMO 0509
64 (NVNUMB(18))	Type of middle clouds, C_M (code) WMO 0515
65 (NVNUMB(19))	Type of low clouds, C_L (code) WMO 0513
66 (NVNUMB(20))	Cloud base height (N_h) (code) WMO 2700
67 (NVNUMB(21))	Low cloud amount (N) (code) WMO 2700
68 (NVNUMB(22))	Additional cloud group height (h_s, h_s) (m)
69 (NVNUMB(23))	Additional cloud group type (C) (code) WMO 0500
70 (NVNUMB(24))	Additional cloud group amount (N_s) (code) WMO 2700
71 (NVNUMB(25))	Snow depth (S_d) (m)
72 (NVNUMB(26))	State of ground (E) (code) WMO 0901
73 (NVNUMB(27))	Ground temperature (T_g, T_g) (K)
74 (NVNUMB(28))	Special phenomena (S_p, S_p) (code) WMO 3778
75 (NVNUMB(29))	Special phenomena (s_p, s_p) (code) WMO 3778
76 (NVNUMB(30))	Ice code type (R_s) (code) WMO 3551
77 (NVNUMB(31))	Ice thickness (E_s, E_s) (m) (code) WMO 1751
78 (NVNUMB(32))	Ice (I_s) (code) WMO 1751
79 (NVNUMB(33))	Time period of rain information (t_r, t_r) (hour)
80 (NVNUMB(34))	6 hr rain amount (liquid part) (kg/m^2)
81 (NVNUMB(35))	Max. temperature (JJ) (K)
82 (NVNUMB(36))	Ship speed (V_s) (m/s)
83 (NVNUMB(37))	Ship direction (D_s) (degrees)
84 (NVNUMB(38))	Wave heigh (H_w, H_w) (m)
85 (NVNUMB(39))	Wave period (P_w, P_w) (s)
86 (NVNUMB(40))	Wave direction (D_w, D_w) (degrees)
87 (NVNUMB(41))	General cloud group (code) WMO 20012
88 (NVNUMB(42))	Relative humidity from low clouds (%)
89 (NVNUMB(43))	Relative humidity from middle clouds (%)
90 (NVNUMB(44))	Relative humidity from high clouds (%)
91 (NVNUMB(45))	Total amount of clouds (code) WMO 20011
92 (NVNUMB(46))	6 hr snow fall (solid part of the rain) (m)
110 (NVNUMB(47))	Surface pressure (Pa)
111 (NVNUMB(48))	Wind direction (degrees)
112 (NVNUMB(49))	Wind force (m/s)
119 (NVNUMB(50))	Brightness temperature (K)
120 (NVNUMB(51))	Raw radiance (K)
121 (NVNUMB(52))	Cloud amount from satellite (%)



TABLE 6.47 VARIABLE-NUMBER CODES

Code figure	Description
122 (NVNUMB(53))	Sigma0 scatterometer backscatter (dB)
123 (NVNUMB(60))	Cloud liquid water (kg/kg)
124 (NVNUMB(61))	Ambiguous V-component (m/s)
125 (NVNUMB(62))	Ambiguous U-component (m/s)
126 (NVNUMB(64))	Ambiguous wind direction (degrees)
127 (NVNUMB(65))	Ambiguous wind speed (m/s)
130 (NVNUMB(68))	Ozone (DU)
200 (NVNUMB(59))	Aux. variable (numeric)

6.5.7 CDS vertical-coordinate type

TABLE 6.48 VERTICAL COORDINATE TYPE

Code figure	Description
1 (NPRESVC)	Pressure vertical coordinate
2 (NHEIGVC)	Height vertical coordinate
3 (NTOVCVC)	TOVS channel
4 (NSCATCVC)	Scatterometer channel

6.5.8 CDS instrument-type codes

DRIBU/TEMP/PILOT/SATEM/SCATTEROMETER/PAOB/RAW RADIANCE:

Instrument type codes are not defined.

SYNOP/AIREP:

TABLE 6.49 INSTRUMENT TYPE CODES: SYNOP/AIREP

Code figure	Description
32 (NSYNINTP)	Synop instrument type
32 (NSHPINTP)	Ship instrument type
32 (NACFINTP)	Airep instrument type

SATOB:

TABLE 6.50 INSTRUMENT TYPE CODES: SATOB

Code figure	Description
60 (NSTBITGO)	GOES

TABLE 6.50 INSTRUMENT TYPE CODES: SATOB

Code figure	Description
62 (NSTBITME)	Meteosat
63 (NSTBITIN)	Indian SATOB
68 (NSTBITJA)	JAPAN

6.5.9 CDS 5.5.14 retrieval codes

TABLE 6.51 RETRIEVAL CODES

Code figure	Description
1 (NCLEAR)	Clear
2 (NPCLOU)	Partly cloudy
3 (NCLLOUD)	Cloudy

6.5.10 CDS geographical-area codes

CONVENTIONAL OBSERVATIONS:

TABLE 6.52 GEOGRAPHICAL AREA CODES: CONVENTIONAL OBSERVATIONS

Bit	Description
1	Northern Hemisphere (20N-90N)
2	Southern Hemisphere (20S-90S)
3	Tropics (20S-20N)

SATOB:

TABLE 6.53 GEOGRAPHICAL AREA CODES: SATOB

Bit	Description
1	Meteosat
2	Insat
3	Himawari
4	GOES
5	Un-identified

SATEM:

For SATEM the purpose of the geographical-area codes is to separate between different satellites.



6.5.11 CDS SATOB I1 codes, name of country

TABLE 6.54 SATOB I1 CODES, NAME OF COUNTRY

Code figure	Description
0 (NSBI1(1))	Europe
1 (NSBI1(2))	Japan
2 (NSBI1(3))	USA
3 (NSBI1(4))	USSR
4 (NSBI1(5))	India

6.5.12 CDS SATOB I2I2 codes, satellite-indicator figure

TABLE 6.55 SATOB I2I2 CODES, SATELLITE-INDICATOR FIGURE

Code figure	Description
4 (NSBI2I2(1))	Meteosat
177 (NSBI2I2(2))	Pretoria
0 (NSBI2I2(3))	Goes
3 (NSBI2I2(4))	Japan
20 (NSBI2I2(5))	India

6.5.13 CDS SATEM TOVS A, B, C, V, W, X, Y codes

TOVS A CODES

TABLE 6.56 TOVS A CODES

Code figure	Description
0	No HIRS/2 data
1	Clear radiances are derived from clear spots
2	Clear radiances are derived from the N* method

TOVS B CODES

TABLE 6.57 TOVS B CODES

Code figure	Description
0	No HIRS/2 data
1	All HIRS/2 channels were used
2	Tropospheric HIRS/2 channels were unusable due to clouds and only stratospheric channels were used



TOVS C CODES

TABLE 6.58 TOVS C CODES

Code figure	Description
0	Statistical retrieval method used
1	Minimum information retrieval used
2	Minimum information retrieval attempted but statistical retrieval used

TOVS V CODES

TABLE 6.59 TOVS V CODES

Code figure	Description
0	No retrieval
1	HIRS+MSU
2	HIRS

TOVS W CODES

TABLE 6.60 TOVS W CODES

Code figure	Description
0	No retrieval
1	HIRS+MSU
2	HIRS

TOVS X CODES

TABLE 6.61 TOVS X CODES

Code figure	Description
0	No retrieval
1	HIRS(1, 2, 3, 8, 9, 16, 17)+MSU(4)
2	HIRS(1, 2, 3, 8, 9, 16, 17)
3	HIRS(1, 2, 3, 9, 17)+MSU(4)
4	HIRS(1, 2, 3, 9, 17)

TOVS Y CODES



TABLE 6.62 TOVS Y CODES

Code figure	Description
0	No retrieval
1	HIRS+SSU+MSU(3, 4)
2	HIRS+MSU(3, 4)
3	SSU+MSU(3, 4)

TOVS Z CODES

To be defined.

6.5.14 1D-VAR SSM/I surface-type quality control

TABLE 6.63 1D-VAR SSM/I SURFACE TYPE QUALITY CONTROL

Code figure	Description
0	Surface type derived from model land/sea mask is sea surface
1	Surface type derived from model land/sea mask is land surface
2	Surface type derived from model surface temperature is ice surface
3	SSM/I observed brightness temperatures are out of physical bounds

6.5.15 1D-VAR failure indicator

If the code figure is 0 the 1D-VAR minimization went OK, otherwise something went wrong.





Part I: OBSERVATION PROCESSING

CHAPTER 7 BUFR feedback data structure/format

Table of contents

7.1 Basic concept

7.2 TOVS/SSMI/SCAT 'PRESAT' BUFR feedback format

7.2.1 TOVS 'PRESAT': deviations from first guess, estimated bias and estimated standard deviation

7.2.2 TOVS 'PRESAT' 1D VAR retrieval

7.2.3 TOVS 'PRESAT' summary flag

7.2.4 SSMI 'PRESAT' ('PRESSMI'): final departure and estimated bias

7.2.5 SSMI 'PRESAT' ('PRESSMI') 1D VAR retrieval

7.2.6 SCAT 'PRESAT' ('PRESCAT')

7.3 Report events and status

7.3.1 Report events 1 30 bit flag table

7.3.2 Report events 2 30-bit flag table

7.3.3 Report blacklist events 30-bit flag table

7.3.4 Report status 30 bit-flag table

7.4 Analysis variables BUFR feedback format

7.4.1 SYNOP analysis variables

7.4.2 AIREP analysis variables

7.4.3 SATOB analysis variables

7.4.4 DRIBU analysis variables

7.4.5 TEMP analysis variables

7.4.6 PILOT analysis variables

7.4.7 PAOB analysis variables

7.4.9 TOVS radiance

7.4.10 SSMI radiances

7.4.11 SSMI derived variables

7.4.12 SCAT 's

7.4.13 SCAT derived variables



7.5 Analysis variables flags

7.5.1 Datum final-flag feedback format

7.5.2 Datum first-guess check flag feedback format

7.5.5 Datum-blacklist flag-feedback format

7.5.6 Datum-flag 4 bit code table

7.6 Analysis variables events and status

7.6.1 Analysis variables events 1 BUFR feedback format

7.6.2 Analysis variables events 2 BUFR feedback format

7.6.3 Analysis variables blacklist events BUFR feedback format

7.6.4 Analysis variables status BUFR feedback format

7.6.5 Datum events 1 30-bit flag table format

7.6.6 Datum events 2 30 Bit Flag table format

7.6.7 Datum blacklist events (30 bit flag table) format

7.6.8 Datum status (30 bit flag table) format

7.7 Analysis variables quality control constants

7.7.1 Analysis variables probability of gross error BUFR feedback format

7.7.2 Analysis variables range of possible values BUFR feedback format

7.8 Analysis variables error statistics

7.8.1 Analysis variables final observation error BUFR feedback format

7.8.2 Analysis variables prescribed observation error BUFR feedback format

7.8.3 Analysis variables persistence observation error BUFR feedback format

7.8.4 Analysis variables representativeness observation error BUFR feedback format

7.8.5 Analysis variables first-guess observation error BUFR feedback format

7.9 Analysis variables departures

7.9.1 Analysis variables first-guess departure BUFR feedback format

7.9.2 Analysis variables initial (update) departure BUFR feedback format

7.9.3 Analysis variables initial high-resolution (update) departure BUFR feedback format

7.9.4 Analysis variables initial low-resolution (update) departure BUFR feedback format

7.9.5 Analysis variables final low-resolution (update) departure BUFR feedback format

7.9.6 Analysis variables simulation (update) departure BUFR feedback format

7.9.7 Analysis variables final (update) unal (simulation) departure BUFR feedback format



7.1 BASIC CONCEPT

The idea with BUFR feedback data is to store, in addition to the original input BUFR data, all relevant observation-related information gathered during the data-assimilation cycle. This information is:

- 1) TOVS/SSMI/SCAT "PRESAT"
- 2) Report events and status,
- 3) Analysis variables,
- 4) Analysis variables flags:
 - Final flag,
 - First guess flags,
 - Departure flag,
 - Analysis qc flags,
 - Blacklist flags
- 5) Analysis variables events and status:
 - Events 1,
 - Events 2,
 - Blacklist events, and
 - Status
- 6) Analysis variables data qc constants:
 - Probability of gross error, and
 - Range of possible values
- 7) Analysis variables error statistics:
 - Final obs. error,
 - Prescribed obs. error,
 - Persistence obs. error,
 - Representativeness obs. error, and
 - First guess error
- 8) Analysis variables departures:
 - First guess departure,
 - Update departures:
 - Initial update departure,
 - Initial high resolution departure,
 - Initial low resolution departure,
 - Final low resolution departure, and
 - Simulation departure
 - Final analysis departure

This is done, as already said, by appending the original input BUFR data with the new information. Each of the items of information mentioned above forms a separate section. Thus, there may be seven main feedback sections, of which some may have a few subsections. Each of these sections/subsections starts by first declaring what it is, by using BUFR (unexpanded) descriptors followed by the actual information.

The first-mentioned feedback section (TOVS/SSMI/SCAT "PRESAT") exists only in the case of satellite observations.

7.2 TOVS/SSMI/SCAT 'PRESAT' BUFR FEEDBACK FORMAT

7.2.1 TOVS 'PRESAT': deviations from first guess, estimated bias and estimated standard deviation

TABLE 7.1 TOVS 'PRESAT': DEVIATIONS FROM FIRST GUESS, ESTIMATED BIAS, ESTIMATED STANDARD DEVIATION BUFR FEEDBACK FORMAT

Sequence number	BUFR (unexpanded) descriptor	Value	Description
1	225000	Numeric	Difference statistics
2	237000	Numeric	Use previously defined bit map
3	001031	98	Generating centre (ECMWF)
4	001032	80	Generating application ('presat' first-guess deviations)
5	008024	32	Difference statistics
6	101jjj	Numeric	Replicate 1 descriptor jjj times; jjj is no. of channels = 27
7	225255	Value	Difference statistics values/marker
8	001031	98	Generating centre (ECMWF)
9	001032	81	Generating application ("presat" estimated bias)
10	008024	32	Difference statistics
11	101jjj	Numeric	Replicate 1 descriptor jjj times; jjj is no. of channels = 27
12	225255	Value	Difference statistics values/marker
13	001031	98	Generating centre (ECMWF)
14	001032	82	Generating application ('presat' estimated standard deviation)
15	008024	32	Difference statistics
16	101jjj	Numeric	Replicate 1 descriptor jjj times; jjj is no. of channels = 27
17	225255	Value	Difference statistics values/marker

7.2.2 TOVS 'PRESAT' 1D VAR retrieval

TABLE 7.2 TOVS "PRESAT" 1D VAR RETRIEVAL BUFR FEEDBACK FORMAT

Sequence number	BUFR (unexpanded) descriptor	Value	Description
1	001031	98	Generating centre (ECMWF)
2	001032	80	Generating application (1D VAR retrieval)
3	235000	Numeric	Cancel backward reference bit map
4	1mmnnn	Numeric	Replicate mm descriptors nnn times; mm is no. of 1d var variables = 5, nnn is no. of 1d var levels = 40+2
5	007004	Value	<i>p</i>



TABLE 7.2 TOVS "PRESAT" 1D VAR RETRIEVAL BUFR FEEDBACK FORMAT

Sequence number	BUFR (unexpanded) descriptor	Value	Description
6	012001	Value	T_b
7	012001	Value	T_r
8	013001	Value	Q_b
9	013001	Value	Q_r
10	101nnn	Numeric	Replicate 1 descriptor nnn times; nnn is no. of channels = 27
11	033213	Value	1D VAR radiance cost
12	033212	Value	1D VAR iteration no.
13	033214	Value	1D VAR error(s)
14	002193	Value	1D VAR satellite channel(s) used
15	002193	Value	1D VAR satellite channel(s) used

7.2.3 TOVS 'PRESAT' summary flag

TABLE 7.3 TOVS 'PRESAT' SUMMARY FLAG BUFR FEEDBACK FORMAT

Sequence number	BUFR (unexpanded) descriptor	Value	Description
1	001031	98	Generating centre (ECMWF)
2	001032	80	Generating application ("presat")
3	033231	Value	TOVS 'presat' summary flag

7.2.4 SSMI 'PRESAT' ('PRESSMI'): final departure and estimated bias

TABLE 7.4 SSMI 'PRESAT' FINAL DEPARTURE AND ESTIMATED BIAS BUFR FEEDBACK FORMAT

Sequence number	BUFR (unexpanded) descriptor	Value	Description
1	225000	Numeric	Difference statistics
2	237000	Numeric	Use previously defined bit map
3	001031	98	Generating centre (ECMWF)
4	001032	80	Generating application ('pressmi' final departure)
5	008024	32	Difference statistics
6	101jjj	Numeric	Replicate 1 descriptor jjj times; jjj is no. of channels = 7
7	225255	Value	Difference statistics values/marker
8	001031	98	Generating centre (ECMWF)

TABLE 7.4 SSMI 'PRESAT' FINAL DEPARTURE AND ESTIMATED BIAS BUFR FEEDBACK FORMAT

Sequence number	BUFR (unexpanded) descriptor	Value	Description
9	001032	82	Generating application ('pressmi' estimated bias)
10	008024	32	Difference statistics
11	101jjj	Numeric	Replicate 1 descriptor jjj times; jjj is no. of channels = 7
12	225255	Value	Difference statistics values/marker

7.2.5 SSMI 'PRESAT' ('PRESSMI') 1D VAR retrieval

TABLE 7.5 SSMI 'PRESAT' 1D VAR RETRIEVAL BUFR FEEDBACK FORMAT

Sequence number	BUFR (unexpanded) descriptor	Value	Description
1	001031	98	Generating centre (ECMWF)
2	001032	80	Generating application (1D VAR retrieval)
3	235000	Numeric	Cancel backward reference bit map
4	1mmnnn	Numeric	Replicate mm descriptors nnn times; mm is no. of 1d var upperair variables = 7, nnn is no. of 1d var levels = 40
5	007004	Value	p
6	012001	Value	T_b
7	012001	Value	T_a
8	013001	Value	Q_b
9	013001	Value	Q_a
10	013201	Value	Q_{b1}
11	013201	Value	Q_{a1}
12	001031	98	Generating centre (ECMWF)
13	001032	80	Generating application (1D VAR retrieval)
14	235000	Numeric	Cancel backward reference bit map
15	1nnmmm	Numeric	Replicate mm descriptors nnn times; mm is no. of 1d var single level variables = 15, nnn is no. of 1d var levels = 1
16	007004	Value	p
17	012061	Value	T_{bs}
18	012004	Value	T_{b2m}
19	013199	Value	Q_{b2m}
20	013199	Value	Q_{a2m}
21	013016	Value	PWC_b
22	013016	Value	PWC_a



TABLE 7.5 SSMI 'PRESAT' 1D VAR RETRIEVAL BUFR FEEDBACK FORMAT

Sequence number	BUFR (unexpanded) descriptor	Value	Description
23	013016	Value	PWC_e
24	013205	Value	LWP_b
25	013205	Value	LWP_a
26	013205	Value	LWP_e
27	011192	Value	u_{10m}^b
28	011193	Value	v_{10m}^b
29	011012	Value	V_{10m}^a
30	011012	Value	V_{10m}^e
31	101nnn	Numeric	Replicate 1 descriptor nnn times; nnn is no. of channels = 7
32	033213	Value	1D Var radiance cost
33	033216	value	1D VAR surface type qc
34	013202	value	SSMI independent surface type qc
35	033212	value	1D VAR no. of iterations for convergence
36	033217	value	1D VAR failure indicator
37	033218	value	1D VAR estimate of scattering
38	033219	value	SSM/I independent scattering index
39	013203	value	1D VAR estimate of rain rate (mm/h)
40	013204	value	SSMI independent estimate of rain rate (mm/h)
41	033199	value	TPW 1D VAR retrieved errors
42	011210	value	V 1D VAR retrieved errors
43	013210	value	LWP 1D VAR retrieved errors
44	013211	value	TPW independent estimate of errors
45	011211	value	V independent estimate of errors
46	013212	value	LWP independent estimate of errors

7.2.6 SCAT 'PRESAT' ('PRESCAT')

TABLE 7.6 SCAT 'PRESAT' BUFR FEEDBACK FORMAT

Sequence number	BUFR (unexpanded) descriptor	Value		Description
1	001031	98		Generating centre (ECMWF)
2	001032	100		Generating application ('prescat')
3	021226	Value		Backscatter residual distance of first solution
4	021226	Value		Backscatter residual distance of second solution
5	021225	Value		SCAT 'presat' product confidence flag
6	033215	Value		Directional skill

7.3 REPORT EVENTS AND STATUS

TABLE 7.7 REPORT EVENTS AND STATUS BUFR FEEDBACK SECTION

Sequence number	BUFR descriptor	Value		Description
		3D VAR	4D VAR	
1	001031	98		Generating centre (ECMWF)
2	001032	60	64	Generating application
3	033220	31 bit code table		Report events 1 (see 7.3.1)
4	033232	31 bit code table		Report blacklist events (see 7.3.3)
5	033221	31 bit code table		SYNOP report events 2 (see 7.3.2)
	033222			AIREP report events 2 (see 7.3.2)
	033223			SATOB report events 2 (see 7.3.2)
	033224			DRIBU report events 2 (see 7.3.2)
	033225			TEMP report events 2 (see 7.3.2)
	033226			PILOT report events 2 (see 7.3.2)
	033227			SATEM report events 2 (see 7.3.2)
	033228			PAOB report events 2 (see 7.3.2)
	033229			SCAT. report events 2 (see 7.3.2)
	033230			R. RAD. report events 2 (see 7.3.2)
6	033233	13 bit table		Report status (see 7.3.4)



7.3.1 Report events 1 30 bit flag table

TABLE 7.8 ANALYSIS EVENTS 1 BUFR FLAG TABLE (033220) FORMAT

Bit position	Description
1 - 14	Not used
15	Failed quality control
16	Report rejected through namelist
17	Model surface too far from station altitude
18	Missing station altitude
19	Report over sea
20	Report over land
21	Redundant report
22	Time out of range
23	Vertical position out of range
24	Horizontal position out of range
25	Activated by whitelist
26	Activated due to RDB flag
27	Rejected due to RDB flag
28	Bad reporting practice
29	All data rejected
30	No data in the report

7.3.2 Report events 2 30-bit flag table

TABLE 7.9 SYNOP EVENTS 2 BUFR FLAG TABLE (033221) FORMAT

Bit position	Description
1 - 30	Not defined

TABLE 7.10 AIREP EVENTS 2 BUFR FLAG TABLE (033222) FORMAT

Bit position	Description
1 - 30	Not defined

TABLE 7.11 SATOB EVENTS 2 BUFR FLAG TABLE (033223) FORMAT

Bit position	Description
1 - 30	Not defined

TABLE 7.12 DRIBU EVENTS 2 BUFR FLAG TABLE (033224) FORMAT

Bit position	Description
1 - 30	Not defined

TABLE 7.13 TEMP EVENTS 2 BUFR FLAG TABLE (033225) FORMAT

Bit position	Description
1 - 30	Not defined

TABLE 7.14 PILOT EVENTS 2 BUFR FLAG TABLE (033226) FORMAT

Bit position	Description
1 - 30	Not defined

TABLE 7.15 SATEM EVENTS 2 BUFR FLAG TABLE (033227) FORMAT

Bit position	Description
1 - 30	Not defined

TABLE 7.16 PAOB EVENTS 2 BUFR FLAG TABLE (033228) FORMAT

Bit position	Description
1 - 30	Not defined

TABLE 7.17 SCAT EVENTS 2 BUFR FLAG TABLE (033229) FORMAT

Bit position	Description
1 - 29	Not defined
30	Thinned report

TABLE 7.18 R. RAD. EVENTS 2 BUFR FLAG TABLE (033230) FORMAT

Bit position	Description
1 - 30	Not defined



7.3.3 Report blacklist events 30-bit flag table

TABLE 7.19 REPORT BLACKLIST EVENTS BUFR FLAG TABLE (033232) FORMAT

Bit position	Description
1 - 13	Not defined
14	Blacklisted due to distance from ref. point
15	Blacklisted due to model orography
16	Blacklisted due to land/sea mask
17	Station altitude blacklisted
18	Longitude blacklisted
19	Latitude blacklisted
20	Time blacklisted
21	Date blacklisted
22	Instrument type blacklisted
23	Code type blacklisted
24	Station id blacklisted
25	Blacklisted due to first guess departure
26	Blacklisted due to observed value
27	Blacklisted due to type of vertical coordinate
18	Blacklisted due to pressure code
19	Variable name blacklisted
30	Monthly monitoring

7.3.4 Report status 30 bit-flag table

TABLE 7.20 REPORT EVENTS 1 BUFR FLAG TABLE (033233) FORMAT

Bit position	Description
1 - 26	Not defined
27	Report blacklisted
28	Report rejected
29	Report passive
30	Report active

7.4 ANALYSIS VARIABLES BUFR FEEDBACK FORMAT

7.4.1 SYNOP analysis variables

TABLE 7.21 SYNOP ANALYSIS VARIABLES BUFR FEEDBACK FORMAT

Sequence number	BUFR descriptor	Value		Description
		3D VAR	4D VAR	
1	235000	Numeric		Cancel backward reference bit map
2	001031	98		Generating centre (ECMWF)
3	001032	61	65	Generating application
4	007004	Value		p
5	011192	Value		u_{10m}
6	011193	Value		v_{10m}
7	010195	Value		Z
8	012004	Value		T_{2m}
9	013192	Value		RH_{2m}

7.4.2 AIREP analysis variables

TABLE 7.22 AIREP ANALYSIS VARIABLES BUFR FEEDBACK FORMAT

Sequence number	BUFR descriptor	Value		Description
		3D VAR	4D VAR	
1	235000	Numeric		Cancel backward reference bit map
2	001031	98		Generating centre (ECMWF)
3	001032	61	65	Generating application
4	007004	Value		p
5	011003	Value		u
6	011004	Value		v
7	010195	Value		Z
8	012001	Value		T



7.4.3 SATOB analysis variables

TABLE 7.23 SATOB ANALYSIS VARIABLES BUFR FEEDBACK FORMAT

Sequence number	BUFR descriptor	Value		Description
		3D VAR	4D VAR	
1	235000	Numeric		Cancel backward reference bit map
2	001031	98		Generating centre (ECMWF)
3	001032	61	65	Generating application
4	0008003	Code table		Vertical significance (see ECMWF Meteorological Bulletin M1.1/4)
5	010004	Value		p
6	011003	Value		u
7	011004	Value		v

7.4.4 DRIBU analysis variables

TABLE 7.24 DRIBU ANALYSIS VARIABLES BUFR FEEDBACK FORMAT

Sequence number	BUFR descriptor	Value		Description
		3D VAR	4D VAR	
1	235000	Numeric		Cancel backward reference bit map
2	001031	98		Generating centre (ECMWF)
3	001032	61	65	Generating application
4	007004	Value		p
5	011192	Value		u_{10m}
6	011193	Value		v_{10m}
7	010195	Value		Z
8	012004	Value		T_{2m}

7.4.5 TEMP analysis variables

TABLE 7.25 TEMP ANALYSIS VARIABLES BUFR FEEDBACK FORMAT

Sequence number	BUFR descriptor	Value		Description
		3D VAR	4D VAR	
1	235000	Numeric		Cancel backward reference bit map
2	001031	98		Generating centre (ECMWF)
3	001032	61	65	Generating application

TABLE 7.25 TEMP ANALYSIS VARIABLES BUFR FEEDBACK FORMAT

Sequence number	BUFR descriptor	Value		Description
		3D VAR	4D VAR	
4	108000	Numeric		Replicate 8 descriptors by extended delayed replication factor
5	031001	Numeric		Extended delayed replication factor (no. of analysis variables)
6	007004	Value		p
7	008001	Flag table		Vertical sounding significance (see ECMWF Meteorological Bulletin M1.1/4)
8	011003	Value		u
9	011004	Value		v
10	010195	Value		Z
11	012001	Value		T
12	013193	Value		RH
13	013001	Value		Q

7.4.6 PILOT analysis variables

TABLE 7.26 PILOT ANALYSIS VARIABLES BUFR FEEDBACK FORMAT

Sequence number	BUFR descriptor	Value		Description
		3D VAR	4D VAR	
1	235000	Numeric		Cancel backward reference bit map
2	001031	98		Generating centre (ECMWF)
3	001032	61	65	Generating application
4	105000	Numeric		Replicate 5 descriptors by extended delayed replication factor
5	031001	Numeric		Extended delayed replication factor (no. of analysis variables)
6	007004	Value		p
7	008001	Flag table		Vertical sounding significance (see ECMWF Meteorological Bulletin M1.1/4)
5	011003	Value		u
6	011004	Value		v
7	010195	Value		Z



7.4.7 PAOB analysis variables

TABLE 7.27 PAOB ANALYSIS VARIABLES BUFR FEEDBACK FORMAT

Sequence number	BUFR descriptor	Value		Description
		3D VAR	4D VAR	
1	235000	Numeric		Cancel backward reference bit map
2	001031	98		Generating centre (ECMWF)
3	001032	61	65	Generating application
4	010051	Value		p
5	010195	Value		Z

7.4.8 Standard SATEM/TOVS analysis variables

TABLE 7.28 STANDARD SATEM/TOVS ANALYSIS VARIABLES BUFR FEEDBACK FORMAT

Sequence number	BUFR descriptor	Value		Description
		3D VAR	4D VAR	
1	235000	Numeric		Cancel backward reference bit map
2	001031	98		Generating centre (ECMWF)
3	001032	61	65	Generating application
4	103nnn	Numeric		Replicate 3 descriptors nnn times; nnn is no. of layers = 7
5	007004	Value		p_t
6	007004	Value		p_b
7	010195	Value		DZ
8	103nnn	Numeric		Replicate 3 descriptors nnn times; nnn is no. of layers = 3
9	007004	Value		p_t
10	007004	Value		p_b
11	013016	Value		PWC

7.4.9 TOVS radiance

TABLE 7.29 TOVS RADIANCES BUFR FEEDBACK FORMAT

Sequence number	BUFR descriptor	Value		Description
		3D VAR	4D VAR	
1	235000	Numeric		Cancel backward reference bit map
2	001031	98		Generating centre (ECMWF)

TABLE 7.29 TOVS RADIANCES BUFR FEEDBACK FORMAT

Sequence number	BUFR descriptor	Value		Description
		3D VAR	4D VAR	
3	001032	61	65	Generating application
4	101nnn	Numeric		Replicate 1 descriptor nnn times; nnn is no. of channels = 27
5	012062	Value		T_b

7.4.10 SSMI radiances

TABLE 7.30 SSMI RADIANCES BUFR FEEDBACK FORMAT

Sequence number	BUFR descriptor	Value		Description
		3D VAR	4D VAR	
1	235000	Numeric		Cancel backward reference bit map
2	001031	98		Generating centre (ECMWF)
3	001032	61	65	Generating application
4	101nnn	Numeric		Replicate 1 descriptor nnn times; nnn is no. of channels = 7
5	012062	Value		T_b

7.4.11 SSMI derived variables

TABLE 7.31 SSMI DERIVED VARIABLES BUFR FEEDBACK FORMAT

Sequence number	BUFR descriptor	Value		Description
		3D VAR	4D VAR	
1	235000	Numeric		Cancel backward reference bit map
2	001031	98		Generating centre (ECMWF)
3	001032	61	65	Generating application
4	013016	Value		PWC
5	013205	Value		Q_1
6	011012	Value		V



7.4.12 SCAT σ_0 's

TABLE 7.32 SCAT σ_0 BUFR FEEDBACK SECTION

Sequence number	BUFR descriptor	Value		Description
		3D VAR	4D VAR	
1	235000	Numeric		Cancel backward reference bit map
2	001031	98		Generating centre (ECMWF)
3	001032	61	65	Generating application
4	101003	Numeric		Replicate 1 descriptor nnn times; nnn is no. of σ_0 's = 3
5	021192	Value		σ_0

7.4.13 SCAT derived variables

TABLE 7.33 SCAT DERIVED VARIABLES BUFR FEEDBACK SECTION

Sequence number	BUFR descriptor	Value		Description
		3D VAR	4D VAR	
1	235000	Numeric		Cancel backward reference bit map
2	001031	98		Generating centre (ECMWF)
3	001032	61	65	Generating application
4	1nnmmm	Numeric		Replicate mm descriptors nnn times; mm is no. of variables = 2, nnn is no. of pairs = 2
5	011192	value		Ambiguous u_{10m}
6	011193	value		Ambiguous v_{10m}

7.5 ANALYSIS VARIABLES FLAGS

7.5.1 Datum final-flag feedback format

TABLE 7.34 DATUM FINAL-FLAG BUFR FEEDBACK FORMAT

Sequence number	BUFR (unexpanded) descriptor	Value		Description
		3D VAR	4D VAR	
1	222000	Numeric		Quality information follow
2	237000	Numeric		Use previous reference bit map
3	001031	98		Generating centre (ECMWF)
4	001032	62	66	Generating application (analysis flag)

TABLE 7.34 DATUM FINAL-FLAG BUFR FEEDBACK FORMAT

Sequence number	BUFR (unexpanded) descriptor	Value		Description
		3D VAR	4D VAR	
5	Explicit rep.fac.	101jjj	Numeric	Replicate 1 descriptor jjj times; jjj is the no. of flags
	Delayed rep.fac.	101000	Numeric	Replicate 1 descriptor by extended delayed replication factor
6	Explicit rep. fac.	033209	4 bit code table	Final flag (see)
	Delayed rep. fac.	031002	Numeric	Extended delayed replication factor (no. of flags)
7	Explicit rep. fac.	none	None	None
	Delayed rep. fac.	033209	4 bit code table	Final flag (see)

7.5.2 Datum first-guess check flag feedback format

TABLE 7.35 DATUM FIRST-GUESS CHECK FLAG BUFR FEEDBACK FORMAT

Sequence number	BUFR (unexpanded) descriptor	Value		Description
		3D VAR	4D VAR	
1		222000	Numeric	Quality information follow
2		237000	Numeric	Use previous reference bit map
3		001031	98	Identification of originating and generating centre (ECMWF)
4		001032	62 66	Generating application (analysis flag)
5	Explicit rep.fac.	101jjj	Numeric	Replicate 1 descriptor jjj times; jjj is the no. of flags
	Delayed rep.fac.	101000	Numeric	Replicate 1 descriptor by extended delayed replication factor
6	Explicit rep. fac.	033208	4 bit code table	First guess check flag (see)
	Delayed rep. fac.	031002	Numeric	Extended delayed replication factor (no. of flags)
7	Explicit rep. fac.	None	None	None
	Delayed rep. fac.	033208	4 bit code table	First guess check flag (see)



7.5.3 Datum departure check flag feedback format

TABLE 7.36 DATUM DEPARTURE CHECK FLAG BUFR FEEDBACK FORMAT

Sequence number	BUFR (unexpanded) descriptor	Value		Description
		3D VAR	4D VAR	
1	222000	Numeric		Quality information follow
2	237000	Numeric		Use Previous reference bit map
3	001031	98		Identification of originating and generating centre (ECMWF)
4	001032	62	66	Generating application (analysis flag)
5	Explicit rep.fac.	101jjj	Numeric	Replicate 1 descriptor jjj times; jjj is the no. of flags
	Delayed rep.fac.	101000	Numeric	Replicate 1 descriptor by extended delayed replication factor
6	Explicit rep. fac.	033207	4 bit code table	Departure check flag (see)
	Delayed rep. fac.	031002	Numeric	Extended delayed replication factor (no. of flags)
7	Explicit rep. fac.	None	None	None
	Delayed rep. fac.	033207	4 bit code table	Departure check flag (see)

7.5.4 Datum analysis QC flag feedback format

TABLE 7.37 DATUM ANALYSIS QC FLAG BUFR FEEDBACK FORMAT

Sequence number	BUFR (unexpanded) descriptor	Value		Description
		3D VAR	4D VAR	
1	222000	Numeric		Quality information follow
2	237000	Numeric		Use previous reference bit map
3	001031	98		Identification of originating/generating centre (ECMWF)
4	001032	62	66	Generating application (analysis flag)
5	Explicit rep.fac.	101jjj	Numeric	Replicate 1 descriptor jjj times; jjj is the no. of flags
	Delayed rep.fac.	101000	Numeric	Replicate 1 descriptor by extended delayed replication factor
6	Explicit rep. fac.	033206	4 bit code table	Analysis qc flag (see)
	Delayed rep. fac.	031002	Numeric	Extended delayed replication factor (no. of flags)

TABLE 7.37 DATUM ANALYSIS QC FLAG BUFR FEEDBACK FORMAT

Sequence number	BUFR (unexpanded) descriptor	Value		Description
		3D VAR	4D VAR	
7	Explicit rep. fac.	none	None	none
	Delayed rep. fac.	033206	4 bit code table	Analysis qc flag (see)

7.5.5 Datum-blacklist flag-feedback format

TABLE 7.38 DATUM-BLACKLIST FLAG BUFR FEEDBACK FORMAT

Sequence number	BUFR (unexpanded) descriptor	Value		Description
		3D VAR	4D VAR	
1	222000	Numeric		Quality information follow
2	237000	Numeric		Use Previous reference bit map
3	001031	98		Identification of originating/generating centre (ECMWF)
4	001032	62	66	Generating application (analysis flag)
5	Explicit rep.fac.	101jjj	Numeric	Replicate 1 descriptor jjj times; jjj is the no. of flags
	Delayed rep.fac.	101000	Numeric	Replicate 1 descriptor by extended delayed replication factor
6	Explicit rep. fac.	033205	4 bit code table	Blacklist flag (see)
	Delayed rep. fac.	031002	Numeric	Extended delayed replication factor (no. of flags)
7	Explicit rep. fac.	None	None	None
	Delayed rep. fac.	033205	4 bit code table	Blacklist flag (see)

7.5.6 Datum-flag 4 bit code table

TABLE 7.39 DATUM-FLAG BUFR CODE TABLES (033205/033206/033207/033208/033209) FORMAT

Value	Description
0	Datum correct
1	Datum probably correct
2	Datum probably incorrect
3	Datum incorrect
4-14	Not used



7.6 ANALYSIS VARIABLES EVENTS AND STATUS

7.6.1 Analysis variables events 1 BUFR feedback format

TABLE 7.40 DATUM EVENTS 1 BUFR FEEDBACK FORMAT

Sequence number	BUFR (unexpanded) descriptor	Value		Description
		3D VAR	4D VAR	
1	222000	Numeric		Quality information follow
2	237000	Numeric		Use previous reference bit map
3	001031	98		Identification of originating/generating centre (ECMWF)
4	001032	63	67	Generating application (analysis events/status)
5	Explicit rep.fac. 101jjj	Numeric		Replicate 1 descriptor jjj times; jjj is the no. of datum events 1
	Delayed rep.fac. 101000	Numeric		Replicate 1 descriptor by extended delayed replication factor
6	Explicit rep. fac. 033236	30 bit flag table		Datum events 1 (see 7.6.5)
	Delayed rep. fac. 031002	Numeric		Extended delayed replication factor (no. of datum events 1)
7	Explicit rep. fac. None	None		None
	delayed rep. fac. 033236	30 bit flag table		Datum events 1 (see 7.6.5)

7.6.2 Analysis variables events 2 BUFR feedback format

TABLE 7.41 DATUM EVENTS 2 BUFR FEEDBACK FORMAT

Sequence number	BUFR (unexpanded) descriptor	Value		Description
		3D VAR	4D VAR	
1	222000	Numeric		Quality information follow
2	237000	Numeric		Use previous reference bit map
3	001031	98		Identification of originating/generating centre (ECMWF)
4	001032	63	67	Generating application (analysis events/status)
5	Explicit rep.fac. 101jjj	Numeric		Replicate 1 descriptor jjj times; jjj is the no. of datum events 2
	Delayed rep.fac. 101000	Numeric		Replicate 1 descriptor by extended delayed replication factor

TABLE 7.41 DATUM EVENTS 2 BUFR FEEDBACK FORMAT

Sequence number	BUFR (unexpanded) descriptor	Value		Description
		3D VAR	4D VAR	
6	Explicit rep. fac.	033237	30 bit flag table	SYNOP datum events 2 (see 7.6.6)
		033238		AIREP datum events 2 (see 7.6.6)
		033239		SATOB datum events 2 (see 7.6.6)
		033240		DRIBU datum events 2 (see 7.6.6)
		033243		TEMP datum events 2 (see 7.6.6)
		033244		PILOT datum events 2 (see 7.6.6)
		033245		SATEM datum events 2 (see 7.6.6)
		033246		PAOB datum events 2 (see 7.6.6)
		033247		SCAT datum events 2 (see 7.6.6)
		033248		R. RAD. datum events 2 (see 7.6.6)
	Delayed rep. fac.	031002	Numeric	Extended delayed replication factor (no. of datum events 2)
7	Explicit rep. fac.	None	None	None
		033237	30 bit flag table	SYNOP analysis events 2 (see 7.6.2)
		033238		AIREP analysis events 2 (see 7.6.2)
		033239		SATOB analysis events 2 (see 7.6.2)
		033240		DRIBU analysis events 2 (see 7.6.2)
		033243		TEMP analysis events 2 (see 7.6.2)
		033244		PILOT analysis events 2 (see 7.6.2)
		033245		SATEM analysis events 2 (see 7.6.2)
		033246		PAOB analysis events 2 (see 7.6.2)
		033247		SCAT analysis events 2 (see 7.6.2)
	Delayed rep. fac.	033248		R. RAD. analysis events 2 (see 7.6.2)

7.6.3 Analysis variables blacklist events BUFR feedback format

TABLE 7.42 DATUM BLACKLIST EVENTS BUFR FEEDBACK FORMAT

Sequence number	BUFR (unexpanded) descriptor	Value		Description
		3D VAR	4D VAR	
1	222000		Numeric	Quality information follow
2	237000		Numeric	Use previous reference bit map
3	001031		98	Identification of originating/generating centre (ECMWF)
4	001032	63	67	Generating application (analysis events/status)



TABLE 7.42 DATUM BLACKLIST EVENTS BUFR FEEDBACK FORMAT

Sequence number	BUFR (unexpanded) descriptor	Value		Description
		3D VAR	4D VAR	
5	explicit rep.fac.	101jjj	Numeric	Replicate 1 descriptor jjj times; jjj is the no. of blacklist events
	delayed rep.fac.	101000	Numeric	Replicate 1 descriptor by extended delayed replication factor
6	explicit rep. fac.	033249	30 bit flag table	Blacklist analysis events (see 7.6.7)
	delayed rep. fac.	031002	Numeric	Extended delayed replication factor (no. of blacklist events)
7	explicit rep. fac.	None	None	None
	delayed rep. fac.	033249	30 bit flag table	Blacklist analysis events (see 7.6.7)

7.6.4 Analysis variables status BUFR feedback format

TABLE 7.43 DATUM STATUS BUFR FEEDBACK FORMAT

Sequence number	BUFR (unexpanded) descriptor	Value		Description
		3D VAR	4D VAR	
1		222000	Numeric	Quality information follow
2		237000	Numeric	Use previous reference bit map
3		001031	98	Identification of originating/generating centre (ECMWF)
4		001032	63 67	Generating application (analysis events/status)
5	Explicit rep.fac.	101jjj	Numeric	Replicate 1 descriptor jjj times; jjj is the no. of datum statuses
	Delayed rep.fac.	101000	Numeric	Replicate 1 descriptor by extended delayed replication factor
6	Explicit rep. fac.	033236	30 bit flag table	Analysis status (see 7.6.8)
	Delayed rep. fac.	031002	Numeric	Extended delayed replication factor (no. of datum statuses)
7	Explicit rep. fac.	None	None	None
	Delayed rep. fac.	033234	30 bit flag table	Analysis status (see 7.6.8)

7.6.5 Datum events 1 30-bit flag table format

TABLE 7.44 DATUM EVENTS 1 BUFR FLAG TABLE (033236) FORMAT

Bit position	Description
1 - 3	Not defined
4	Variational qc performed
5	Datum rejected due to rejected report
6	Combined flagging
7	Datum rejected through namelist
8	Vertical coordinate changed from Z to p
9	Vertical consistency check
10	Level selection
11	Multi level check
12	Too many surface levels
13	Duplicated datum/level
14	Not an analysis layer
15	Report over see
16	Report over land
17	Redundant level
18	Redundant datum
19	Too big obs. error
20	Too big departure in assimilation
21	Too big first guess departure
22	Reference level position out of range
23	Vertical position out of range
24	Bad reporting practice
25	Activated by whitelist
26	Activated due to RDB flag
27	Rejected due to RDB flag
28	Missing first guess value
29	Missing observed value
30	Missing vertical coordinate



7.6.6 Datum events 2 30 Bit Flag table format

TABLE 7.45 SYNOP DATUM EVENTS 2 BUFR FLAG TABLE (033237) FORMAT

Bit position	Description
1 - 30	Not defined

TABLE 7.46 AIREP DATUM EVENTS 2 BUFR FLAG TABLE (033238) FORMAT

Bit position	Description
1 - 30	Not defined

TABLE 7.47 SATOB DATUM EVENTS 2 BUFR FLAG TABLE (033239) FORMAT

Bit position	Description
1 - 30	Not defined

TABLE 7.48 DRIBU DATUM EVENTS 2 BUFR FLAG TABLE (033240) FORMAT

Bit position	Description
1 - 30	Not defined

TABLE 7.49 TEMP DATUM EVENTS 2 BUFR FLAG TABLE (033243) FORMAT

Bit position	Description
1 - 30	Not defined

TABLE 7.50 PILOT DATUM EVENTS 2 BUFR FLAG TABLE (033244) FORMAT

Bit position	Description
1 - 30	Not defined

TABLE 7.51 SATEM DATUM EVENTS 2 BUFR FLAG TABLE (033245) FORMAT

Bit position	Description
1 - 25	Not defined
	Not predefined layer
	Layer formed by thinning up

TABLE 7.51 SATEM DATUM EVENTS 2 BUFR FLAG TABLE (033245) FORMAT

Bit position	Description
	Layer formed by summing up
	Channel not used in analysis
30	Overwritten by ADVAR

TABLE 7.52 PAOB DATUM EVENTS 2 BUFR FLAG TABLE (033246) FORMAT

Bit position	Description
1 - 30	Not defined

TABLE 7.53 SCAT DATUM EVENTS 2 BUFR FLAG TABLE (033247) FORMAT

Bit position	Description
1 - 30	Not defined

TABLE 7.54 R. RAD. DATUM EVENTS 2 BUFR FLAG TABLE (033238) FORMAT

Bit position	Description
1 - 30	Not defined

7.6.7 Datum blacklist events (30 bit flag table) format

TABLE 7.55 DATUM BLACKLIST EVENTS FLAG TABLE (033249) FORMAT

Bit position	Description
1 - 29	Not defined
30	Pressure blacklisted

7.6.8 Datum status (30 bit flag table) format

TABLE 7.56 DATUM STATUS BUFR FLAG TABLE (033234) FORMAT

Bit position	Description
1 - 26	Not defined
27	Datum blacklisted
28	Datum rejected
29	Datum passive



TABLE 7.56 DATUM STATUS BUFR FLAG TABLE (033234) FORMAT

Bit position	Description
30	Datum active

7.7 ANALYSIS VARIABLES QUALITY CONTROL CONSTANTS

7.7.1 Analysis variables probability of gross error BUFR feedback format

TABLE 7.57 PROBABILITY OF GROSS ERROR BUFR FEEDBACK FORMAT

Sequence number	BUFR (unexpanded) descriptor	Value		Description
		3D VAR	4D VAR	
1	222000	Numeric		Quality information follow
2	237000	Numeric		Use previous reference bit map
3	001031	98		Identification of originating/generating centre (ECMWF)
4	001032	61	65	Generating application
5	Explicit rep.fac.	101jjj	Numeric	Replicate 1 descriptor jjj times; jjj is the no. errors
	Delayed rep.fac.	101000	Numeric	Replicate 1 descriptor by extended delayed replication factor
6	Explicit rep. fac.	033250	Value	Probability of gross error
	Delayed rep. fac.	031002	Numeric	Extended delayed replication factor (no. of errors)
7	Explicit rep. fac.	None	None	None
	Delayed rep. fac.	033250	Value	Probability of gross error

7.7.2 Analysis variables range of possible values BUFR feedback format

TABLE 7.58 DATUM RANGE OF POSSIBLE VALUES BUFR FEEDBACK FORMAT

Sequence number	BUFR (unexpanded) descriptor	Value		Description
		3D VAR	4D VAR	
1	222000	Numeric		Quality information follow
2	237000	Numeric		Use previous reference bit map
3	001031	98		Identification of originating/generating centre (ECMWF)
4	001032	61	65	Generating application



TABLE 7.58 DATUM RANGE OF POSSIBLE VALUES BUFR FEEDBACK FORMAT

Sequence number	BUFR (unexpanded) descriptor	Value		Description
		3D VAR	4D VAR	
5	Explicit rep.fac.	101jjj	Numeric	Replicate 1 descriptor jjj times; jjj is the no. of values
	Delayed rep.fac.	101000	Numeric	Replicate 1 descriptor by extended delayed replication factor
6	explicit rep. fac.	033251	Value	Range of possible values
	delayed rep. fac.	031002	Numeric	Extended delayed replication factor (no. of values)
7	explicit rep. fac.	None	None	None
	delayed rep. fac.	033251	Value	Range of possible values

7.8 ANALYSIS VARIABLES ERROR STATISTICS

7.8.1 Analysis variables final observation error BUFR feedback format

TABLE 7.59 FINAL OBSERVATION ERROR BUFR FEEDBACK FORMAT

Sequence number	BUFR (unexpanded) descriptor	Value		Description
		3D VAR	4D VAR	
1	224000		Numeric	First order statistics
2	237000		Numeric	Use previous reference bit map
3	001031		98	Identification of originating/generating centre (ECMWF)
4	001032	61	65	Generating application
5	008023		35	First-order statistics (35 = final obs. error)
6	Explicit rep.fac.	101jjj	Numeric	Replicate 1 descriptor jjj times; jjj is the no. errors
	Delayed rep.fac.	101000	Numeric	Replicate 1 descriptor by extended delayed replication factor
7	Explicit rep. fac.	224255	Value	First-order statistics values/marker
	Delayed rep. fac.	031002	Numeric	Extended delayed replication factor (no. of errors)
8	Explicit rep. fac.	None	None	None
	Delayed rep. fac.	224255	Value	First-order statistics values/marker



7.8.2 Analysis variables prescribed observation error BUFR feedback format

TABLE 7.60 PRESCRIBED OBSERVATION ERROR BUFR FEEDBACK FORMAT

Sequence number	BUFR (unexpanded) descriptor	Value		Description
		3D VAR	4D VAR	
1	224000	Numeric		First order statistics
2	237000	Numeric		Use previous reference bit map
3	001031	98		Identification of originating/generating centre (ECMWF)
4	001032	61	65	Generating application
5	008023	33		First order statistics (33 = prescribed obs. error)
6	Explicit rep.fac.	101jjj	Numeric	Replicate 1 descriptor jjj times; jjj is the no. errors
	Delayed rep.fac.	101000	Numeric	Replicate 1 descriptor by extended delayed replication factor
7	Explicit rep. fac.	224255	Value	First order statistics values/maker
	Delayed rep. fac.	031002	Numeric	Extended delayed replication factor (no. of errors)
8	Explicit rep. fac.	None	None	None
	Delayed rep. fac.	224255	Value	First order statistics values/maker

7.8.3 Analysis variables persistence observation error BUFR feedback format

TABLE 7.61 PERSISTENCE OBSERVATION ERROR BUFR FEEDBACK FORMAT

Sequence number	BUFR (unexpanded) descriptor	Value		Description
		3D VAR	4D VAR	
1	224000	Numeric		First order statistics
2	237000	Numeric		Use previous reference bit map
3	001031	98		Identification of originating/generating centre (ECMWF)
4	001032	61	65	Generating application
5	008023	34		First order statistics (34 = persistence obs. error)
6	Explicit rep.fac.	101jjj	Numeric	Replicate 1 descriptor jjj times; jjj is the no. errors
	Delayed rep.fac.	101000	Numeric	Replicate 1 descriptor by extended delayed replication factor
7	Explicit rep. fac.	224255	Value	First order statistics values/marker
	Delayed rep. fac.	031002	Numeric	Extended delayed replication factor (no. of errors)

TABLE 7.61 PERSISTENCE OBSERVATION ERROR BUFR FEEDBACK FORMAT

Sequence number	BUFR (unexpanded) descriptor	Value		Description
		3D VAR	4D VAR	
8	Explicit rep. fac.	None	None	None
	Delayed rep. fac.	224255	Value	First order statistics values/marker

7.8.4 Analysis variables representativeness observation error BUFR feedback format

TABLE 7.62 REPRESENTATIVENESS OBSERVATION ERROR BUFR FEEDBACK FORMAT

Sequence number	BUFR (unexpanded) descriptor	Value		Description
		3D VAR	4D VAR	
1	224000	Numeric		First order statistics
2	237000	Numeric		Use previous reference bit map
3	001031	98		Identification of originating/generating centre (ECMWF)
4	001032	61	65	Generating application
5	008023	36		First order statistics (36 = representativeness obs. error)
6	Explicit rep.fac.	101jjj	Numeric	Replicate 1 descriptor jjj times; jjj is the no. of representativeness obs. errors)
	Delayed rep.fac.	101000	Numeric	Replicate 1 descriptor by extended delayed replication factor
7	Explicit rep. fac.	224255	Value	First order statistics values/marker
	Delayed rep. fac.	031002	Numeric	Extended delayed replication factor (no. representativeness obs. errors)
8	Explicit rep. fac.	None	None	None
	Delayed rep. fac.	224255	Value	First order statistics values/marker

7.8.5 Analysis variables first-guess observation error BUFR feedback format

TABLE 7.63 FIRST-GUESS ERROR BUFR FEEDBACK FORMAT

Sequence number	BUFR (unexpanded) descriptor	Value		Description
		3D VAR	4D VAR	
1	224000	Numeric		First order statistics
2	237000	Numeric		Use previous reference bit map
3	001031	98		Identification of originating/generating centre (ECMWF)
4	001032	61	65	Generating application



TABLE 7.63 FIRST-GUESS ERROR BUFR FEEDBACK FORMAT

Sequence number	BUFR (unexpanded) descriptor		Value		Description
			3D VAR	4D VAR	
5		008023		32	First order statistics (32 = first guess error)
6	Explicit rep. fac.	101jjj		Numeric	Replicate 1 descriptor jjj times; jjj is the no. of first guess errors
	Delayed rep. fac.	101000		Numeric	Replicate 1 descriptor by extended delayed replication factor
7	Explicit rep. fac.	224255		Value	First order statistics values/marker
	Delayed rep. fac.	031002		Numeric	Extended delayed replication factor (no. of first guess errors)
8	Explicit rep. fac.	None		None	None
	Delayed rep. fac.	224255		Value	First order statistics values/marker

7.9 ANALYSIS VARIABLES DEPARTURES

7.9.1 Analysis variables first-guess departure BUFR feedback format

TABLE 7.64 FIRST-GUESS DEPARTURE BUFR FEEDBACK FORMAT

Sequence number	BUFR (unexpanded) descriptor		Value		Description
			3D VAR	4D VAR	
1		225000		Numeric	Difference statistics
2		237000		Numeric	Use previous reference bit map
3		001031		98	Identification of originating/generating centre (ECMWF)
4		001032	61	65	Generating application
5		008024		32	Difference statistics (32 = first guess departure)
6	Explicit rep. fac.	101jjj		Numeric	Replicate 1 descriptor jjj times; jjj is the no. of first guess departures
	Delayed rep. fac.	101000		Numeric	Replicate 1 descriptor by extended delayed replication factor (
7	Explicit rep. fac.	225255		Value	Difference statistics values/marker
	Delayed rep. fac.	031002		Numeric	Extended delayed replication factor (no. of first guess departures)
8	Explicit rep. fac.	None		None	None
	Delayed rep. fac.	225255		Value	Difference statistics values/marker

7.9.2 Analysis variables initial (update) departure BUFR feedback format

TABLE 7.65 INITIAL (UPDATE) DEPARTURE BUFR FEEDBACK FORMAT

Sequence number	BUFR (unexpanded) descriptor		Value		Description
			3D VAR	4D VAR	
1		225000	Numeric		Difference statistics
2		237000	Numeric		Use previous reference bit map
3		001031	98		Identification of originating/generating centre (ECMWF)
4		001032	61	65	Generating application
5		008024	33		Difference statistics (33 = analysis departure)
6		033210	Numeric (1,9)		Incremental variational analysis update no.
7		033211	0		Simulation no. (0 = initial departure)
8	Explicit rep. fac.	101jjj	Numeric		Replicate 1 descriptor jjj times; jjj is the no. of departures
	Delayed rep. fac.	101000	Numeric		Replicate 1 descriptor by extended delayed replication factor
9	Explicit rep. fac.	225255	Value		Difference statistics values/marker
	Delayed rep. fac.	031002	Numeric		Extended delayed replication factor (no. of departures)
10	Explicit rep. fac.	None	None		None
	Delayed rep. fac.	225255	Value		Difference statistics/marker

7.9.3 Analysis variables initial high-resolution (update) departure BUFR feedback format

TABLE 7.66 INITIAL HIGH-RESOLUTION (UPDATE) DEPARTURE BUFR FEEDBACK FORMAT

Sequence number	BUFR (unexpanded) descriptor		Value		Description
			3D VAR	4D VAR	
1		225000	Numeric		Difference statistics
2		237000	Numeric		Use previous reference bit map
3		001031	98		Identification of originating/generating centre (ECMWF)
4		001032	61	65	Generating application
5		008024	33		Difference statistics (33 = analysis departure)
6		033210	Numeric (1,9)		Incremental variational analysis update no.
7		033211	1001		Simulation no. (1001 = initial high resolution departure)



TABLE 7.66 INITIAL HIGH-RESOLUTION (UPDATE) DEPARTURE BUFR FEEDBACK FORMAT

Sequence number	BUFR (unexpanded) descriptor	Value		Description
		3D VAR	4D VAR	
8	Explicit rep. fac.	101jjj	Numeric	Replicate 1 descriptor jjj times; jjj is the no. of departures
	Delayed rep. fac.	101000	Numeric	Replicate 1 descriptor by extended delayed replication factor
9	Explicit rep. fac.	225255	Value	Difference statistics values/marker
	Delayed rep. fac.	031002	Numeric	Extended delayed replication factor (no. of departures)
10	Explicit rep. fac.	None	None	None
	Delayed rep. fac.	225255	Value	Difference statistics values/marker

7.9.4 Analysis variables initial low-resolution (update) departure BUFR feedback format

TABLE 7.67 INITIAL LOW-RESOLUTION (UPDATE) DEPARTURE BUFR FEEDBACK FORMAT

Sequence number	BUFR (unexpanded) descriptor	Value		Description
		3D VAR	4D VAR	
1		225000	Numeric	Difference statistics
2		237000	Numeric	Use previous reference bit map
3		001031	98	Identification of originating/generating centre (ECMWF)
4		001032	61 65	Generating application
5		008024	33	Difference statistics (33 = analysis departures)
6		033210	Numeric (1,9)	Incremental variational analysis update no.
7		033211	1002	Simulation no. (1002 = initial low resolution departure)
8	Explicit rep. fac.	101jjj	Numeric	Replicate 1 descriptor jjj times; jjj is the no. of departures
	Delayed rep. fac.	101000	Numeric	Replicate 1 descriptor by extended delayed replication factor
9	Explicit rep. fac.	225255	Value	Difference statistics values/marker
	Delayed rep. fac.	031002	Numeric	Extended delayed replication factor (no. of departures)
10	Explicit rep. fac.	None	None	None
	Delayed rep. fac.	225255	Value	Difference statistics values/marker

**7.9.5 Analysis variables final low-resolution (update) departure BUFR feedback format**

TABLE 7.68 FINAL LOW-RESOLUTION (UPDATE) DEPARTURE BUFR FEEDBACK FORMAT

Sequence number	BUFR (unexpanded) descriptor		Value		Description
			3D VAR	4D VAR	
1		225000	Numeric		Difference statistics
2		237000	Numeric		Use previous reference bit map
3		001031	98		Identification of originating/generating centre (ECMWF)
4		001032	61	65	Generating application
5		008024	33		Difference statistics (33 =analysis departure)
6		033210	Numeric (1,9)		Incremental variational analysis update no.
7		033211	999		Simulation no. (999 = final departure)
8	Explicit rep. fac.	101jjj	Numeric		Replicate 1 descriptor jjj times; jjj is the no. of departures
	Delayed rep. fac.	101000	Numeric		Replicate 1 descriptor by extended delayed replication factor
9	Explicit rep. fac.	225255	Value		Difference statistics values/marker
	Delayed rep. fac.	031002	Numeric		Extended delayed replication factor (no. of departures)
10	Explicit rep. fac.	none	none		none
	Delayed rep. fac.	225255	value		Difference statistics values/marker

7.9.6 Analysis variables simulation (update) departure BUFR feedback format

TABLE 7.69 SIMULATION (UPDATE) DEPARTURE BUFR FEEDBACK FORMAT

Sequence number	BUFR (unexpanded) descriptor		Value		Description
			3D VAR	4D VAR	
1		225000	Numeric		Difference statistics
2		237000	Numeric		Use previous reference bit map
3		001031	98		Identification of originating/generating centre (ECMWF)
4		001032	61	65	Generating application
5		008024	33		Difference statistics (33 = analysis departures)
6		033210	Numeric (1,9)		Incremental variational analysis update no.
7		033211	Numeric (1,999)		Simulation no.



TABLE 7.69 SIMULATION (UPDATE) DEPARTURE BUFR FEEDBACK FORMAT

Sequence number	BUFR (unexpanded) descriptor	Value		Description
		3D VAR	4D VAR	
8	Explicit rep. fac.	101jjj	Numeric	Replicate 1 descriptor jjj times; jjj is the no. of departures
	Delayed rep. fac.	101000	Numeric	Replicate 1 descriptor by extended delayed replication factor
9	Explicit rep. fac.	225255	Value	Difference statistics values/marker
	Delayed rep. fac.	031002	Numeric	Extended delayed replication factor (no. of departures)
10	Explicit rep. fac.	None	None	None
	Delayed rep. fac.	225255	Value	Difference statistics values/marker

7.9.7 Analysis variables final (update) uinal (simulation) departure BUFR feedback format

TABLE 7.70 FINAL (UPDATE) FINAL (SIMULATION) DEPARTURE BUFR FEEDBACK FORMAT

Sequence number	BUFR (unexpanded) descriptor	Value		Description
		3D VAR	4D VAR	
1		225000	Numeric	Difference statistics
2		237000	Numeric	Use previous reference bit map
3		001031	98	Identification of originating/generating centre (ECMWF)
4		001032	61 65	Generating application
5		008024	33	Difference statistics (33 = analysis departures)
6		033210	9	Incremental variational analysis update no. (9 = final update)
7		033211	999	Simulation no. (999 = Final departure)
8	Explicit rep. fac.	101jjj	Numeric	Replicate 1 descriptor jjj times; jjj is the no. of departures
	Delayed rep. fac.	101000	Numeric	Replicate 1 descriptor by extended delayed replication factor
9	Explicit rep. fac.	225255	Value	Difference statistics values/marker
	Delayed rep. fac.	031002	Numeric	Extended delayed replication factor (no. of departures)
10	Explicit rep. fac.	None	None	None
	Delayed rep. fac.	225255	Value	Difference statistics values/marker



**Part I: OBSERVATION PROCESSING****CHAPTER 8 SIMULATED-observations data structure/format****Table of contents**

- [8.1 Standard/converted SIMULATED-observations structure/format](#)
- [8.2 Standard/converted SIMULATED-observations DDR format](#)
- [8.3 Standard/converted SIMULATED-observations report header format](#)
- [8.4 Standard SIMULATED observations report body entry format](#)
- [8.5 Converted SIMULATED observations report body entry format](#)

8.1 STANDARD/CONVERTED SIMULATED-OBSERVATIONS STRUCTURE/FORMAT

These are very simple unformatted structures consisting of a DDR (data-descriptor record) and a number of data records. The DDR is real two words long, whereas data records (reports) are also reals but of a variable length. Data reports logically consist of two parts: report header and report body. The report header is 10 words long. On the other hand the report body consists of a number of body entries. The standard SIMULATED observation body entry is 26 words long but the CONVERTED one is 10 words long. For missing values there is a SIMULATED observations missing indicator set to -99999.

8.2 STANDARD/CONVERTED SIMULATED-OBSERVATIONS DDR FORMAT

TABLE 8.1 STANDARD/CONVERTED SIMULATED OBSERVATIONS DDR FORMAT

Word	Type	Content
1	R	Date (YYYYMMDD)
2	R	Time (hhmmss)

8.3 STANDARD/CONVERTED SIMULATED-OBSERVATIONS REPORT HEADER FORMAT

TABLE 8.2 STANDARD/CONVERTED SIMULATED REPORT HEADER FORMAT

Word	Type	Content
1	R	Report len. in words
2	R	Observation type (CMA style)
3	R	Observation code type (CMA style)

TABLE 8.2 STANDARD/CONVERTED SIMULATED REPORT HEADER FORMAT

Word	Type	Content
4	R	Latitude (degrees)
5	R	Longitude (degrees)
6	R	Altitude (m)
7	R	Date (YYYYMMDD)
8	R	Time (hhmmss)
9	R	No. of levels
10	R	Quality informations

8.4 STANDARD SIMULATED OBSERVATIONS REPORT BODY ENTRY FORMAT

TABLE 8.3 STANDARD SIMULATED REPORT BODY ENTRY FORMAT

Word	Type	Content
1	R	p_t (pa)/Channel no. (numeric)
2	R	p_r (pa)
3	R	u (m s^{-1})
4	R	σ_0^u (m s^{-1})
5	R	v (m s^{-1})
6	R	σ_0^v (m s^{-1})
7	R	Z (m)
8	R	σ_0^Z (m)
9	R	T (K)
10	R	σ_0^T (K)
11	R	T_d (K)
12	R	$\sigma_0^{T_d}$ (K)
13	R	RH (0,1)
14	R	σ_0^{RH} (0,1)
15	R	Q (kg kg^{-1})
16	R	σ_0^Q (kg kg^{-1})
17	R	DZ (m)
18	R	σ_0^{DZ} (m)
19	R	PWC (mm)
20	R	σ_0^{PWC} (mm)
21	R	$\partial u / \partial z$ (s^{-1})
22	R	$\sigma_0^{\partial u / \partial z}$ (s^{-1})
23	R	$\partial v / \partial z$ (s^{-1})



TABLE 8.3 STANDARD SIMULATED REPORT BODY ENTRY FORMAT

Word	Type	Content
24	R	$\sigma_0^{\partial v/\partial z} (s^{-1})$
25	R	$T_b (K)$
26	R	$\sigma_0^{T_b} (K)$
27	R	$T_b^{\text{bias}} (K)$

8.5 CONVERTED SIMULATED OBSERVATIONS REPORT BODY ENTRY FORMAT

TABLE 8.4 CONVERTED SIMULATED REPORT BODY ENTRY FORMAT

Word	Type	Content
1	R	p_t (pa)/channel no. (numeric)
2	R	p_r (pa)
3	R	DDD (degrees)/ u ($m s^{-1}$)
4	R	FFF/v ($m s^{-1}$)
5	R	Z (m)
6	R	T (K)
7	R	T_d (K)
8	R	PWC (mm)
9	R	T_b (K)
10	R	σ^0 (dB)



**Part I: OBSERVATION PROCESSING****CHAPTER 9 NAMELISTS****Table of contents**

9.1 NAMRUN
9.2 NAMGLP
9.3 NAMIO
9.4 NAMNUMC
9.5 NAMCMA
9.6 NAMBUFR
9.7 NAMSIM
9.8 NAMOCMA
9.9 NAMSSMI
9.10 NAMDIA
9.11 NAMMKCMA
9.12 NAMFDBAC
9.13 NAMTOOLS
9.14 NAMERR
9.15 NAMLVLY

9.1 NAMRUN

Table 9.1 OBSPROC run-parameters namelist NAMRUN

Name	Type	Meaning	Default
LMKCMA	L	MAKECMA task switch	False
LCMAMERG	L	ECMA CCMA merge switch	False
LFEEDBAC	L	FEEDBACK task switch	False
LBFDBACK	L	BUFR FEEDBACK switch	False
LCFDBACK	L	Old CMA FEEDBACK switch	False
LTOOLS	L	TOOLS task switch	False
LOBSSTAT	L	Obs. statistics (RMS) task switch (not used)	False
LOBSPLOT	L	Obs. statistics (PLOT) ask switch (not used)	False
LMPP	L	MPP mode switch	False



Table 9.1 OBSPROC run-parameters namelist NAMRUN

Name	Type	Meaning	Default
LCOLLECT	L	collect CMA+BUFR data in proc#1switch	False
LSPREAD	L	spread CMA+BUFR data in FEEDBACK task	False
LMATCHUP	L	ECMA CCMA matchup before feedback switch	False
LADJMER	L	internal memory adjustments for obs. requirements switch	False
LCMASORT	L	CMA/BUFR sort at the end of MAKECMA task switch	False
LFREACMA	L	read final ECMA rather than using matchup passed arrays switch	False
LFWRICMA	L	write final ECMA out by matchup	False

9.2 NAMGLP

Table 9.2 OBSPROC global switches/parameters namelist NAMGLP

Name	Type	Meaning	Default
L3DVAR	L	3D VAR analysis run switch	False
L3DFGAT	L	3D VAR FGAT analysis run switch	False
LINCREM	L	3D/4D VAR incremental run switch	False
LCANARI	L	Canary run switch	False
NANDAT	I	Analysis data (YYYYMMDD)	999999
NANTIM	I	Analysis time (HHMMSS)	999999
NANCDY	I	Analysis century day (not used)	none
NANHOU	I	Analysis time in hours from 00Z (not used)	None
NANMIN	I	Analysis time in minutes from 00Z (not used)	None
NTBMAR	I	Backward time margin (in minutes) from analysis time	-180
NTFMAR	I	Forward time margin (in minutes) from analysis time	180
N4DMIN	I	4D VAR analysis time length (in minutes)	0
NMX6HTSL	I	Max. no. of 6 hour time slots	5
NMXBFPTS	I	Max. no. of input BUFR files per 6 hour time slot	7
NMXSFPTS	I	Max. no. of SIMULATED obs. files per 6 hour time slot	1
NMXTSL	I	Max. no. of time slots	1
NMXCMA	I	Max. no of CMA files	1
NMXBF	I	Max. no. of BUFR files	6
NO6HTSL	I	No. of 6 hour time slots	1
NOBFPTS	I	No. of BUGR files per 6 hour time slot	7
NOSFPTS	I	No. of SIMULATED obs. files per 6 hour time slot	0
NOCFPTS	I	No. of old CMA files per 6 hour time slot	0
NOTSL	I	No. of time slots	1



Table 9.2 OBSPROC global switches/parameters namelist NAMGLP

Name	Type	Meaning	Default
NOCMA	I	No. of CMA files	1
NOBF	I	No. of BUFR files	1
NTIMSL	I	Time slot for one CMA file in minutes	7
NCENDA	I	Central day in 4D time interval relative to start	0
NCENHO	I	Central hour in 4D time interval relative to start	4
OBNLAT	R	Northern lat. of observation area	90 ^o
OBSLAT	R	Southern lat. of observation area	-90 ^o
OBWLON	R	Western lon. of observation area	-180 ^o
OBELON	R	Eastern lon. of observation area	180 ^o
EXNLAT	R	Northern lat. of observation exclusion area	90 ^o
EXSLAT	R	Southern lat. of observation exclusion	-90 ^o
EXWLON	R	Western lon. of observation exclusion area	-180 ^o
EXELON	R	Eastern lon. of observation exclusion area	180 ^o
LSYNOP	L	CMA SYNOP obs. switch	True
LCD011	L	CMA SYNOP code type 11 switch	True
LCD014	L	CMA SYNOP code type 14 switch	True
LCD021	L	CMA SYNOP code type 21 switch	True
LCD022	L	CMA SYNOP code type 22 switch	True
LCD023	L	CMA SYNOP code type 23 switch	True
LCD024	L	CMA SYNOP code type 24 switch	True
LAIREP	L	CMA AIREP obs. switch	True
LCD041	L	CMA AIREP code type 41 switch	True
LCD141	L	CMA AIREP code type 141 switch	True
LCD142	L	CMA AIREP code type 142 switch	True
LCD144	L	CMA AIREP code type 144 switch	True
LCD145	L	CMA AIREP code type 145 switch	True
LCD241	L	CMA AIREP code type 241 switch	True
LSATOB	L	CMA SATOB obs. switch	True
LCD088	L	CMA SATOB code type 88 switch	True
LCD089	L	CMA SATOB code type 89 switch	True
LCD090	L	CMA SATOB code type 90 switch	True
LCD188	L	MA SATOB code type 188 switch	False
LODRIBU	L	CMA DRIBU obs. switch	True
LCD063	L	CMA DRIBU code type 63 switch	True
LCD064	L	CMA DRIBU code type 64 switch	True
LCD165	L	CMA DRIBU code type 165 switch	True

Table 9.2 OBSPROC global switches/parameters namelist NAMGLP

Name	Type	Meaning	Default
LCD160	L	CMA DRIBU code type 160 switch	False
LTEMP	L	CMA TEMP obs. switch	True
LCD035	L	CMA TEMP code type 35 switch	True
LCD036	L	CMA TEMP code type 36 switch	True
LCD037	L	CMA TEMP code type 37 switch	True
LCD135	L	CMA TEMP code type 135 switch	True
LCD137	L	CMA TEMP code type 137 switch	False
LCD039	L	CMA TEMP code type 39 switch	True
LCD040	L	CMA TEMP code type 40 switch	True
LOPILOT	L	CMA PILOT obs. switch	True
LCD032	L	CMA PILOT code type 32 switch	True
LCD033	L	CMA PILOT code type 33 switch	True
LCD034	L	CMA PILOT code type 34 switch	True
LSATEM	L	CMA SATEM obs. switch	True
LCD086	L	CMA SATEM code type 86 switch	True
LCD186	L	CMA SATEM code type 186 switch	True
LCD185	L	CMA SATEM code type 185 switch	False
LCD184	L	CMA SATEM code type 184 switch	False
LCD200	L	CMA SATEM code type 200 switch	False
LCD201	L	CMA SATEM code type 201 switch	False
LCD202	L	CMA SATEM code type 202 switch	False
LCD210	L	CMA SATEM code type 210 switch	True
LCD211	L	CMA SATEM code type 211 switch	True
LCD212	L	CMA SATEM code type 212 switch	True
LCD215	L	CMA SATEM 215 switch	True
LOPAOB	L	CMA PAOB obs. switch	True
LCD180	L	CMA PAOB code type 180 switch	True
LSCATT	L	CMA SCAT. obs. switch	True
LCD008	L	CMA SCAT. code type 8 switch	True
LCD122	L	CMA SCAT. code type 122 switch	True
LCD210SC	L	CMA SCAT. code type 210 switch	True
LRARAD	L	CMA R. RADIANCE obs. switch	False
LCD001	L	CMA R. RADIANCE code type 1 switch	False
LBOTLSUR	L	BUFR LAND SURFACE obs. switch	True
LBSSTSY	L	BUFR LAND SURFACE subtype 1 switch	True
LBSSTH1	L	BUFR LAND SURFACE subtype 2 (internal) switch	True



Table 9.2 OBSPROC global switches/parameters namelist NAMGLP

Name	Type	Meaning	Default
LBSSTSA	L	BUFR LAND SURFACE subtype 9 switch	True
LBSSTH2	L	BUFR LAND SURFACE subtype 10 (internal) switch	True
LBSSTAS	L	BUFR LAND SURFACE subtype 3 switch	True
LBSSTH3	L	BUFR LAND SURFACE subtype 4 (internal) switch	True
LBOTSSUR	L	BUFR SEA SURFACE obs. switch	True
LBSSTD1	L	BUFR SEA SURFACE subtype 21 switch	True
LBSSTAS	L	BUFR SEA SURFACE subtype 13 switch	True
LBSSTRS	L	BUFR SEA SURFACE subtype 19 switch	True
LBSSTS1	L	BUFR SEA SURFACE subtype 11 switch	True
LBSSTS2	L	BUFR SEA SURFACE subtype 9 switch	True
LBSSTD2	L	BUFR SEA SURFACE subtype 22 switch	True
LBSSTD3	L	BUFR SEA SURFACE subtype 23 switch	True
LBOTUPAS	L	BUFR UPPERAIR SOUNDINGS obs. switch	True
LBUSSTPI	L	BUFR UPPERAIR SOUNDINGS subtype 91 switch	True
LBUSSTPS	L	BUFR UPPERAIR SOUNDINGS subtype 92 switch	True
LBUSSTWP	L	BUFR UPPERAIR SOUNDINGS subtype 95 switch	True
LBUSSTTS	L	BUFR UPPERAIR SOUNDINGS subtype 102 switch	True
LBUSSTTD	L	BUFR UPPERAIR SOUNDINGS subtype 103 switch	True
LBUSSTTM	L	BUFR UPPERAIR SOUNDINGS subtype 106 switch	True
LBUSSTTE	L	BUFR UPPERAIR SOUNDINGS subtype 101 switch	True
LBOTSATS	L	BUFR SATELLITE SOUNDINGS obs. switch	True
LBSSTHT1	L	BUFR SATELLITE SOUNDINGS subtype 0 switch	True
LBSSTHT2	L	BUFR SATELLITE SOUNDINGS subtype 51 switch	True
LBSSTHT3	L	BUFR SATELLITE SOUNDINGS subtype 53 switch	True
LBSSTHT4	L	BUFR SATELLITE SOUNDINGS subtype 54 switch	True
LBSSTPAO	L	BUFR SATELLITE SOUNDINGS subtype 180 switch	True
LBSSTSLT	L	BUFR SATELLITE SOUNDINGS subtype 61 switch	True
LBSSTSPW	L	BUFR SATELLITE SOUNDINGS subtype 62 switch	True
LBSSTSHT	L	BUFR SATELLITE SOUNDINGS subtype 63 switch	True
LBSSTSME	L	BUFR SATELLITE SOUNDINGS subtype 65 switch	True
LBSSTTLT	L	BUFR SATELLITE SOUNDINGS subtype 71 switch	True
LBSSTPW	L	BUFR SATELLITE SOUNDINGS subtype 72 switch	True
LBSSTTHT	L	BUFR SATELLITE SOUNDINGS subtype 73 switch	True
LBSSTTME	L	BUFR SATELLITE SOUNDINGS subtype 75 switch	True
LBOTAIRE	L	BUFR AIREP obs. switch	True
LBAISTAI	L	BUFR AIREP subtype 142 switch	True

Table 9.2 OBSPROC global switches/parameters namelist NAMGLP

Name	Type	Meaning	Default
LBAISTCO	L	BUFR AIREP subtype 143 switch	True
LBAISTAM	L	BUFR AIREP subtype 144 switch	True
LBAISTAC	L	BUFR AIREP subtype 145 switch	True
LBOTSATO	L	BUFR SATOB obs. switch	True
LBSOSTTW	L	BUFR SATOB subtype 82 switch	True
LBSOSTWO	L	BUFR SATOB subtype 83 switch	True
LBSOSTT1	L	BUFR SATOB subtype 84 switch	False
LBSOSTT2	L	BUFR SATOB subtype 85 switch	False
LBSOST86	L	BUFR SATOB subtype 86 switch	True
LBSOST87	L	BUFR SATOB subtype 87 switch	True
LBOTERS1	L	BUFR SCAT. obs. switch	True
LBERST01	L	BUFR SCAT. subtype 8 switch	True
LBERST02	L	BUFR SCAT. subtype 122 switch	True
LBERST03	L	BUFR SCAT. subtype 127 switch	True
LBOTPAOB	L	BUFR PAOB obs. switch	True
LBPAST01	L	BUFR PAOB subtype 164 switch	True

9.3 NAMIO

Table 9.3 OBSPROC I/O switches/parameters namelist NAMIO

Name	Type	Meaning	Default
LBUFERIO	L	BUFRIN/OUT switch	False
LIEEEOUT	L	Output IEEE conversion switch	True
LIEEEIN	L	Input IEEE conversion switch	True
LOBUFSIN	L	Output BUFR reports to be written one by one switch	True
LOCMASIN	L	Output CMA reports to be written one by one	True
LNEWCMAIO	L	CMA I/O library switch	True
LNEWBUFRIO	L	BUFR I/O library switch	False
LSYNCWRITE	L	Synchronize large block CMA & BUFR I/O-write between PEs	True
LSYNCREAD	L	Synchronize large block CMA & BUFR I/O-read between PEs	True
NSYNCLIM	I	Synchronize I/O if block size > nsynclimc	128 · 1024



9.4 NAMNUMC

Table 9.4 OBSPROC numerical constants/parameters namelist NAMNUMC

Name	Type	Meaning	Default
NOBITS	I	No. of bits per integer word	32
NOBYTES	I	No. of bytes per word	8
RALPHA	R	α convergence test constant	0.1
RBETA	R	β convergence test constant	0.1
RGAMA	R	γ convergence test constant	0.1

9.5 NAMCMA

Table 9.5 OBSPROC CMA switches/parameters namelist NAMCMA

Name	Type	Meaning	Default
LICMAMER	L	Input CMA memory resident switch	False
LOCMAMER	L	Output CMA memory resident switch	False
NODEPT	I	No. of additional departure words	1
NRESUPD	I	No. of reserved updates	1
NUSDUPD	I	No. of used updates	0
NO1DVLV	I	No. of 1D VAR levels (TOVS)	40
NO1DVVA	I	No. of 1D VAR upperair variables (TOVS)	5
NO1DVSLV	I	No. of 1D VAR single level variables (TOVS)	16
NO1DVLVA	I	No. of 1D VAR levels (ATOVS)	40
NO1DVVAA	I	No. of 1D VAR upperair variables (ATOVS) c	5
NO1DVSLVA	I	No. of 1D VAR single level variables (ATOVS)	16
NO1DVLVS	I	No. of 1D VAR upperair variables (SSMI)	40
NO1DVVAS	I	No. of 1D VAR upperair variables (SSMI)	7
NO1DSLVS	I	No. of 1D VAR single level variables (SSMI)	15
LMODPRF	L	Model profiles at obs. points switch	False
NOMODLV	I	No. of model levels	31
NOMODUV	I	No. of model upper air variables	4
NOMODSV	I	No. model single (surface) variables	15
LMPSYNOP	L	Model profile at SYNOP obs. points switch	False
LMPAIREP	L	Model profile at AIREP obs. points switch	False
LMPSATOB	L	Model profile at SATOB obs. points switch	False
LMPDRIBU	L	Model profile at DRIBU obs. points switch	False

Table 9.5 OBSPROC CMA switches/parameters namelist NAMCMA

Name	Type	Meaning	Default
LMPTEMP	L	Model profile at TEMP obs. points switch	False
LMPPILOT	L	Model profile at PILOT obs. points switch	False
LMPSATEM	L	Model profile at SATEM obs. points switch	False
LMPPAOB	L	Model profile at PAOB obs. points switch	False
LMPSCAT	L	Model profile at SCAT. obs. points switch	False
LMPRAWR	L	Model profile at R. RADIANCE obs. points switch	False
LTOVSOH	L	TOVS extended optional CMA header switch	True
LTOPASS	L	TOVS optional passed on parameters switch	True
LTO1DVA	L	TOVS optional 1D VAR related parameters switch	True
LTO1DSL	L	TOVS optional 1D VAR single level parameters switch	True
LTO1DUL	L	TOVS optional 1D VAR upper air parameters switch	True
LTOBICO	L	TOVS optional bias correction parameters switch	False
LSSMIOH	L	SSMI extended optional CMA header switch	True
LSSPASS	L	SSMI optional passed on parameters switch	True
LSS1DVA	L	SSMI optional 1D VAR related parameters switch	True
LSS1DSL	L	SSMI optional 1D VAR single level parameters switch	True
LSS1DUL	L	SSMI optional 1D VAR upper air parameters switch	True
LATOVOH	L	ATOVS extended optional CMA header switch	True
LATPASS	L	ATOVS optional passed on parameters switch	True
LAT1DVA	L	ATOVS optional 1D VAR related parameters switch	True
LAT1DSL	L	ATOVS optional 1D VAR single level parameters switch	True
LAT1DUL	L	ATOVS optional 1D VAR upper air parameters switch	True
LATBICO	L	ATOVS optional bias correction parameters switch	False
NMXGICML	I	Max. len. of integer global CMA array	1
NMXGRCML	I	Max. len. of real global CMA array	
NMXCRL	I	Max. len. of CMA report	
NMXNVO	I	Max. no of levels	300

9.6 NAMBUFR

TABLE 9.6 OBSPROC BUFR-SWITCHES/PARAMETERS NAMELIST NAMBUFR

Name	Type	Meaning	Default
LCONVF()	L	Conventional input BUFR observations files switch	False
LTOVSF()	L	TOVS input BUFR observations files switch	False
LATOVF()	L	ATOVS input BUFR observations files switch	False



TABLE 9.6 OBSPROC BUFR-SWITCHES/PARAMETERS NAMELIST NAMBUFR

Name	Type	Meaning	Default
LSCATF()	L	SCAT. input BUFR observations files switch	False
LSSMIF()	L	SSMI input BUFR observations files switch	False
LGEOSF()	L	GEOS input BUFR observations files switch	False
LAUXBF()	L	AUX. input BUFR observations files switch	False
LFDBBF	L	Temporary BUFR feedback files switch	True
NBFDATE()	I	Input BUFR files dates	0
NBFTIME()	I	Input BUFR files times	0
LBUFRFC	L	BUFR format checking switch	True
LBFCFAIL	L	BUFR format check fail switch	True
LBIGVALU	L	BUFR packing of big values switch	False
LSPEEDUP	L	BUFR software speed-up switch	True
LBSSPLIT	L	BUFR software multi subset split switch	False
LBSCOMPR	L	BUFR software compression switch	False
LHATBUEN	L	BUFR hat encoder switch	True
LBOPRPRO	L	BUFR obs. pre-processing switch	False
LIBUFMER	L	Input BUFR obs. memory resident switch	False
LOBUFMER	L	Output BUFR memory resident switch	False
NMXGIBUL	I	Max. len. of BUFR input global integer array	8193
NMXGRBUL	I	Max. len. of BUFR input global real array	8193
NMXBR	I	Max. no. of BUFR reports	200000
NPBFLI	I	Max. len. of BUFR record	8193
NPSUP	I	Len. of BUFR supplementary array	9
NPSEC0	I	Len. of BUFR section 0	3
NPSEC1	I	Len. of BUFR section 1	40
NPSEC2	I	Len. of BUFR section 2	64
NPSEC3	I	Len. of BUFR section 3	4
NPSEC4	I	Len. of BUFR section 4	2
NPKEY	I	Len. of BUFR key	46
NPELEM	I	Len. of BUFR descriptor array	20000
NPVALS	I	Len. of BUFR values array	80000
NPCVALS	I	Len. of BUFR character array	80000
NPDREP	I	Len. of BUFR "delayed" array	100
NPPLELM	I	Max. 1st dimension of platforms BUFR values array	2000
NPPLPKT	I	Max. no. of BUFR reports to be compressed	250
NPPLPFM	I	Max. no. of platforms to be accumulated	7
NPTSELM	I	Max. 1st dimension of SATEM/TOVS BUFR values array	2000

TABLE 9.6 OBSPROC BUFR-SWITCHES/PARAMETERS NAMELIST NAMBUFR

Name	Type	Meaning	Default
NPTSPKT	I	Max. no. of BUFR SATEM/TOVS reports to be compressed	40
NPTSPFM	I	Max. no. of SATEM/TOVS platforms to be accumulated	2
NPATSELM	I	Max. 1st dimension of ATOVS BUFR values array	2000
NPATSPKT	I	Max. no. of BUFR ATOVS reports to be compressed	40
NPATSPFM	I	Max. no. of ATOVS platforms to be accumulated	2
NPSMELM	I	Max. 1st dimension of SSMI BUFR values array	2000
NPSMPKT	I	Max. no. of SSMI BUFR reports to be compressed	40
NPSMPFM	I	Max. no. of SSMI platforms to be accumulated	2
NPSCELM	I	Max. 1st dimension of SCAT. BUFR values array	320
NPSCPCT	I	Max. no. of SCAT. BUFR reports to be compressed	250
NPSCPFM	I	Max. no. of SCAT. platforms to be accumulated	1
NBUFRED()	I	List of acceptable BUFR editions	3
NPBUFRE	I	Len. of NBUFRED	1

9.7 NAMSIM

TABLE 9.7 OBSPROC SIMULATED-OBSERVATIONS SWITCHES/PARAMETERS NAMELIST NAMSIM

Name	Type	Meaning	Default
LSIMULF()	L	SIMULATED obs. files switch	False
LISIMMER	L	Input SIMULATED obs. memory resident switch	False
NMXGISML	I	Max. len. of global integer simulated obs. array	1
NMXGRSML	I	Max. len. of global real simulated obs. array	136000
NMXSRL	I	Max. len. of simulated obs. array	1360

9.8 NAMOCMA

Table 9.8 OBSPROC old CMA switches namelist NAMOCMA

Name	Type	Meaning	Default
LOCMAF	L	Old CMA file switch	False
LIOCMMER	L	Input old CMA memory resident switch	False
LOOCMMER	L	Output old CMA memory resident switch	False
LOCM2NCM	L	Old to new CMA conversion switch	False
LNCM2OCM	L	New to old CMA conversion switch	False



9.9 NAMSSMI

Table 9.9 OBSPROC SSMI switches/parameters namelist NAMSSMI

Name	Type	Meaning	Default
NMXSMLI	I	Max. no. of SSM/I lines in one orbit	4000
NMXSMEL	I	Max. no. of elements in one scan	64
NSSMISKI	I	No. of points to skip along/across scan	4
LSSMITHI	L	SSMI thinning switch	True

9.10 NAMDIA

Table 9.10 OBSPROC diagnostics switches/parameters namelist NAMDIA

Name	Type	Meaning	Default
LOPRCMA	L	Print CMA report(s) switch	False
LOPRCMD	L	Print CMA DDRs switch	False
LOPRBUFR	L	Print BUFR report(s)	False
LDATCO	L	Data coverage plot file from CMA switch	False
LCONVER	L	Convergence test diagnostics switch	False
LCONTEP	L	Convergence test detailed print switch	False
LODEBEN	L	BUFR encoding debug file write out switch	False
LODEBENP	L	BUFR encoding debug print switch	False
LFBDVOUT	L	Convergence test print for further processing switch	False
LUV2W	L	Convergence test u , v conversion to wind switch	False
LANYPR	L	Convergence test print for all of data switch	False
LRMS	L	RMS diagnostics print out switch (not used)	False
LOPREXT	L	Fully extensive print out switch (not used)	False
RDINLAT	R	Northern lat. of obs. diagnostics area	90 ⁰
RDISLAT	R	Southern lat. of obs. diagnostics area	-90 ⁰
RDIWLON	R	Western lon. of obs. diagnostics area	-180 ⁰
RDIELON	R	Eastern lon. of obs. diagnostics area	180 ⁰
NOCTRQ	I	Observation/code type diagnostics request	999
NOBNUM	I	Observation no. diagnostics request	0
NSKIPBR()	I	List of BUFR messages no. to skip	0
NBURAN1	I	Starting BUFR message no. to write it out for diagnostics	0
NBURAN2	I	Ending BUFR message no. to write it out for diagnostics	0

9.11 NAMMKCMA

TABLE 9.11 OBSPROC MAKECMA-SWITCHES/PARAMETERS NAMELIST NAMMKCMA

Name	Type	Meaning	Default
LNOEDGES	L	No obs. at time edges in 4D VAR to be taken switch	False
LZTCONS	L	T-Z consistency check switch	True
LSPEHUM	L	Specific humidity (Q) switch	True
LQERRFRH	L	Q obs. error dependency on RH obs. error switch	True
LQERRFT	L	Q obs. error dependency on T obs. error switch	False
LQERRFP	L	Q obs. error dependency on p obs. error switch	False
LIFDBACK	L	Feedback BUFR file initialisation switch	True
LTENDCOR	L	Pressure tendency correction switch	False
LERRPERS	L	Persistence error switch	True
LIFSCOMM	L	IFS communication file creation switch	False
LSCATINT	L	SCAT. interface switch	True
LSINOSOL	L	SCAT. interface "no solution" diagnostics switch	False
LSCATTHI	L	SCAT. thinning switch	True
LTOTSCTH	L	Total SCAT. thinning switch	False
NTHINSCA	I	SCAT. thinning factor (1,2,4=25, 50, 100km)	4
NMKCMVSE()	I	List of variables (per obs./code type) to be selected for CMA	
NBUFRVSE()	I	List of variables (per obs./code type) to be selected from BUFR	
NOSORTSL	I	No. of time slots in 4D VAR time sorting	1
LSURPR	L	Surface pressure as an analysis variable switch	True

9.12 NAMFDBAC

Table 9.12 OBSPROC FEEDBACK switches/parameters namelist NAMFBAC

Name	Type	Meaning	Default
LFDBKPR	L	Feedback print before encoding switch	False
LFBREVST	L	Report event/status feedback switch	True
LFBREVE1	L	Report events 1 feedback switch	True
LFBRBLEV	L	Report blacklist events feedback switch	True
LFBREVE2	L	Report events 2 feedback switch	True
LFBRSTAT	L	Report status feedback switch	True
LFBDFLAG	L	Datum flags feedback switch	True
LFBDGFL	L	Datum first guess flags feedback switch	True



Table 9.12 OBSPROC FEEDBACK switches/parameters namelist NAMFBAC

Name	Type	Meaning	Default
LFBDANFL	L	Datum analysis flags feedback switch	True
LFBDLFL	L	Datum blacklist flags feedback switch	True
LFBDDEFL	L	Datum departure flags feedback switch	True
LFBDFIFL	L	Datum final flags feedback switch	True
LFBDDEVST	L	Datum events/status	True
LFBDVE1	L	Datum events 1 feedback switch	True
LFBDBLEV	L	Datum blacklist events feedback switch	True
LFBDVE2	L	Datum events 2 feedback switch	True
LFBDSTAT	L	Datum status feedback switch	True
LFBDQCCO	L	Datum QC constants 1,2 feedback switch	True
LNEWQCCO	L	Datum new style QC constants 1,2 feedback switch	True
LFBDDEPT	L	Datum departures feedback switch	True
LFBDFGDE	L	Datum first guess departure feedback switch	True
LFBDANDE	L	Datum analysis feedback switch	True
LFBDUIDE	L	Datum update initial departure feedback switch	False
LFBDUHDE	L	Datum update high res. departure feedback switch	True
LFBDULID	L	Datum update initial low res. departure feedback switch	True
LFBDULFD	L	Datum update final low res. departure feedback switch	True
LFBDSIDE	L	Datum simulation departures feedback switch	True
LFBDFIDE	L	Datum final final departure feedback switch	True
LEMULDEP	L	Departure emulation switch	False
LFEEETPR	L	Feedback thickness/PWC/radiances together switch	True
LFEEETP	L	Feedback thickness/PWC switch	True
LTHPWTOG	L	Feedback thickness/PWC together switch	True
LFEEEDRA	L	Feedback radiances switch	True
LPRESAFB	L	TOVS presat feedback switch	True
LPREASFB	L	ATOVS presat feedback switch	True
LSTO1DVT	L	1D VAR temperatures store and feedback switch	False
LPRESSFB	L	SSMI presat feedback switch	False
LPRESCFB	L	SCAT. presat feedback switch	True
LSINGFBF	L	Single BUFR feedback file switch	False
LNEWSFES	L	New style flag/event/status feedback switch	True
LNEWFLST	L	New style BUFR feedback flag structure switch	True
LNBUFRTB	L	New BUFR table flag/event/status feedback switch	True
LBITSHIF	L	1 bit shift BUFR flag/event/status feedback switch	True
LBUFRCOM	L	BUFR feedback compression switch	False

Table 9.12 OBSPROC FEEDBACK switches/parameters namelist NAMFBAC

Name	Type	Meaning	Default
LTOVSCOM	L	TOVS/ATOVS BUFR feedback compression switch	False
LSSMICOM	L	SSMI BUFR feedback compression switch	False
LSCATCOM	L	SCATT. BUFR feedback compression switch	False
LFDBKMUP	L	CMA BUFR matchup check switch	True
LFDBKOCC	L	CMA BUFR obs./code type matchup switch	True
LFDBKDTC	L	CMA BUFR date/time matchup switch	True
LFDBKPOC	L	CMA BUFR position matchup switch	True
LFDBKSIC	L	CMA BUFR station id. matchup switch	True
LFBDERRS	L	Datum error statistics feedback switch	True
LFBDIFIER	L	Datum final error feedback switch	True
LFBDOWER	L	Datum obs. error feedback switch	True
LFBDPEER	L	Datum persistence error feedback switch	True
LFBDREER	L	Datum representativeness error feedback switch	True
LFBDGGER	L	Datum first guess error feedback switch	True

9.13 NAMTOOLS

TABLE 9.13 OBSPROC TOOLS-SWITCHES/PARAMETERS NAMELIST NAMTOOLS

Name	Type	Meaning	Default
LBUFTOOL	L	BUFR tool switch	False
LSPLITR	L	BUFR split switch	False
LBUGDE	L	BUFR decode debug switch	True
LBUGEN	L	BUFR encode debug switch	False
LBUGKY	L	BUFR key encode debug switch	False
LBUGRE	L	BUFR decode range debug switch	False
NOTIBFTL	L	Total no. of BUFR files	False
LCMATOOL	L	CMA tool switch	False
LCMAFD	L	Not used	False
LSIMTOOL	L	SIMULATED obs. tool switch	False
LSIMCONV	L	SIMULATED obs. conversion switch	False



9.14 NAMERR

Table 9.14 OBSPROC observation-error switches/parameters namelist NAMERR

Name	Type	Meaning	Default
LERRTHI	L	Thickness obs. errors switch	False
LERRPWC	L	PWC obs. errors switch	False
LHEAREAD	L	Height obs. errors area dependency switch	False
LRHERRMO	L	Rel. hum. obs. errors modelled switch	True
LPERERCO	L	Persistence error evaluation via IFS common routines switch	False
LFINERCO	L	Final obs. errors evaluation via IFS common routines switch	False

9.15 NAMLVLY

Table 9.15 OBSPROC observation-level/layer switches/parameters namelist NAMLVLY

Name	Type	Meaning	Default
LOBTHLAY	L	Observed thickness layers to be used switch	True
LOBPWLAY	L	Observed PWC layers to be used switch	True
NOTHLAY	I	No. of thickness layers	15
NOPWLAY	I	No. of PWC layers	3
TTHLAY()	R	List of thickness layers top pressures	List
BTHLAY()	R	List of thickness layers bottom pressures	List
TPWLAY	R	List of PWC layers top pressures	List
BPWLAY	R	List of PWC layers bottom pressures	List





Part I: OBSERVATION PROCESSING

CHAPTER 10 Processing of scatterometer data

Table of contents

[10.1 Overview](#)

[10.2 Wind retrieval](#)

[10.3 Quality control](#)

[10.4 Bias corrections](#)

10.1 OVERVIEW

Scatterometer data belong to those kinds of observation that need to be transformed into the variables used by the analysis within OBSPROC. The transformation consists here in converting the backscatter coefficient measurements acquired by the instrument (σ^0 triplets) into the two ambiguous u and v wind components that will actually be assimilated into the IFS.

This task is performed within the CMA creation process by the scatterometer data-handling subroutine **SCATSIN** from **OBSCREEN**, and especially by its core subroutine **ERS1IF** (ERS-1 interface). Like **SCATSIN**, **ERS1IF** deals only with one scatterometer report at a time. Moreover, either all or part of the observations can be treated, according to the thinning set up in **SCATSIN**. This thinning, applied only in the screening, is detailed in the corresponding part of the IFS documentation; it is controlled in OBSPROC by logical switches LSCATTHI and LTOTSCTH, which respectively enable its use and make it total, i.e. it invalidates the further processing of those reports that are not to be eventually kept.

The main purpose of **ERS1IF** is to retrieve the wind components by inverting the transfer function relating the backscatter coefficient σ^0 to the wind speed and direction. Some quality control is also done in the process, based on the quality information provided with the raw data as well as on the residual from the wind retrieval, reflecting the agreement between the measurements and their theoretical wind dependency. Moreover, bias corrections are applied, both in terms of σ^0 and of wind speed, particularly to compensate for any change in the instrumental calibration and to ensure consistency between the retrieved and model winds.

The whole procedure follows closely the PRESCAT wind retrieval and ambiguity-removal scheme developed for the ERS-1 scatterometer from the transfer function CMOD4 (*Stoffelen and Anderson, 1997*). Some aspects have already been addressed in *Gaffard and Roquet (1995)*. Also, the description given here applies only to the ERS scatterometer data currently used in the IFS. Different processings would be necessary for data from other instruments such as NSCAT, for example, although the general principles may remain the same. A general reminder about the ERS scatterometers and their measurement geometry can be found in *Stoffelen and Anderson (1997)* as well.

10.2 WIND RETRIEVAL

The wind retrieval is performed by minimizing the following distance from the σ^0 triplets to the cone described by CMOD4 in the backscatter space:

$$D = \sum_{i=1}^3 \left\{ (\sigma_{\text{obs}_i}^0)^{0.625} - (\sigma_{\text{sim}_i}^0)^{0.625} \right\}^2 \quad (10.1)$$

where $\sigma_{\text{obs}_i}^0$ denotes the backscatter coefficient measured by the antenna number i , $i = 1$ (fore), 2 (mid), 3 (aft) and $\sigma_{\text{sim}_i}^0$ denotes the value simulated by CMOD4 from the searched wind-speed and direction. The role of the 0.625 exponent is to make the directional dependency of CMOD4 harmonic, and thus allow a better isotropy of the problem by avoiding direction-trapping effects.

The minimization is achieved using a tabular form of the transfer function, giving the value of the backscatter coefficient for wind speeds, direction angles and incidence angles discretized with steps of 0.5 m s⁻¹, 5 degrees and 1 degree respectively. The corresponding table is read in the initialization subroutine of the scatterometer observation processing **INIERSCA**, called at the beginning of the **MAKECMA** task.

Up to 4 relative minima are kept at first. The first wind-vector solution is then defined as the minimum with the smallest residual, and the second one as the secondary minimum being the closest to the opposite direction and having a residual lower than three times that of the first solution.

The retrieval process is the subject of a dedicated subroutine within **ERS1IF**, **SOTOWIND** returning directly the two ambiguous wind vectors associated with a given σ^0 triplet. This subroutine itself uses two specialized procedures, **SPEEEST** and **MINIMA**, to get a first guess estimate for the wind speeds yielding the lowest residuals and to search for the relative minima in the σ^0 table, respectively.

The retrieved wind components provided by **SOTOWIND** obviously play a major role in the definition of the scatterometer CMA reports. In addition, a logical parameter indicating whether no solution has actually been found is also transmitted for the subsequent processings applied in the IFS; this may happen in the case of measurements leading either to too low or too high winds.

10.3 QUALITY CONTROL

Before calling for the wind retrieval, a first quality control step consists of checking the instrumental quality flag set by ESA and supplied in the scatterometer BUFR file. The data are processed only if they are complete and free from transmission errors or land contaminations, and if no arcings are present for any of the three antennae. The noise to signal ratio K_p must moreover stay smaller than 10% for each antenna, and the missing packet number be less than 10 to ensure that enough individual backscatter measurements have been averaged for estimating the σ^0 value.

A further check is then done on the backscatter residual associated to the rank-1 solution (or, more precisely, its square root so-called 'distance to the cone') if solutions have actually been found. This quantity, representing the misfit between the measured σ^0 s and their theoretical wind-speed and direction dependency, contains both the effects of instrumental noise and of transfer-function errors. These errors can become large locally, when the measurements are affected by geophysical parameters not taken into account by CMOD4, such as sea-state or intense rainfall. Also the distance to the cone is normalized by its expected standard deviation, computed from the K_p value and an estimation of the geophysical noise as a function of wind speed and incidence angle, and the σ^0 triplet considered is rejected if the result exceeds a threshold of 3 (3-standard-deviation test).

Following these quality control checks, a flag is defined. This will be different from zero if any technical problem has been detected during the test of the ESA flag, or if either the distance to the cone has turned out to be too large after wind retrieval or no solutions have even been found. This flag is used in the subsequent processing made in the screening, as described in the corresponding part of the present documentation. The check on the distance to



the cone, essentially local here, is then completed by a global verification aiming at removing cases of instrumental problems not mentioned in the raw data. Both the distance to the cone and the OBSPROC flag are included in the scatterometer CMA reports for that purpose.

10.4 BIAS CORRECTIONS

Two separate bias corrections are included in **ERS1IF** to improve the accuracy of the winds retrieved with CMOD4.

A σ^0 bias correction is first performed before the wind retrieval, by subtracting constant bias estimates from the raw backscatter measurements as a function of their antenna and node numbers. These bias estimates, derived from a routine comparison between the σ^0 s measured by the scatterometer and the σ^0 s simulated by CMOD4 from the first-guess winds of the ECMWF model, are supposed to account both for the variations that may occur in the instrumental calibration in time and for the residual defaults affecting the fit of the transfer function in the backscatter space.

A wind-speed bias correction is then added following the wind retrieval, in the form of a cubic spline function applied to the retrieved wind speeds that is dependent on the measurement node number. The purpose is now to match the scatterometer and model wind speeds over the whole wind-speed range (especially at high winds where CMOD4 tends to be biased low) so as to avoid introducing any speed-up or slow-down tendency in the assimilation process. Like the σ^0 bias correction, this wind-speed-dependent bias correction relies on a direct comparison between scatterometer and model data, in which the wind speeds retrieved with the σ^0 bias correction are fitted as a function of those deduced from the model first guess according to a Maximum Likelihood Estimation (MLE) procedure. However, conventional observations from ships and buoys are also taken into account, to first assess the respective errors of both systems through a triple-collocation analysis. Furthermore, no time variations are considered here, since these are assumed to be already described by the σ^0 bias term.

The σ^0 and wind-speed bias corrections are defined by two dedicated files read in the initialization subroutine IN-IERSCA, and containing appropriate coefficients both for ERS-1 and ERS-2. The σ^0 bias file is normally updated on a monthly basis, the bias applied over a given month being computed from the data from the month before, whilst the wind-speed-bias file is kept constant as a rule. More information about these bias corrections and their derivation can be found in *Le Meur et al. (1997)*.

It should be noted that the corrections made are not kept explicitly in the scatterometer CMA reports, where the main outputs are limited to the retrieved wind components as well as to the distances to the cone and the associated quality-control flags. Moreover, the original σ^0 measurements are also stored, together with the ESA-retrieved wind speeds and directions, to allow subsequent data monitoring from the analysis-feedback file.





Part I: OBSERVATION PROCESSING

REFERENCES

Gaffard, C. and Roquet, H., 1995 : Impact of the ERS-1 scatterometer wind data on the ECMWF 3D-Var assimilation system. ECMWF Tech. Memo. 217.

Le Meur, D., Isaksen, L. and Stoffelen, A., 1997 : Wind speed calibration of ERS scatterometer data for assimilation purposes at ECMWF. Proceedings of the ESA CEOS wind and wave validation workshop held at ESA/ESTEC, Noordwijk, the Netherlands, from June 3–5 1997.

Stoffelen, A. and Anderson, D., 1997 : Ambiguity removal and assimilation of scatterometer data. *Q. J. R. Meteorol. Soc.*, **123**, 491–518.

